

Techniques for Radar and EW Signal Simulation for Receiver Performance Analysis

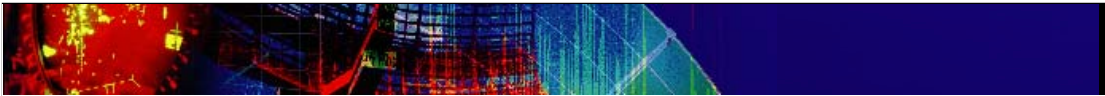

Techniques for Radar and EW Signal Simulation
for Receiver Performance Analysis
Copyright 2004, Agilent Technologies





Agenda

- ➔ **Radar receiver overview**
 - System level testing and performance evaluation
 - Modes of operation
 - Signal processing considerations
 - Signal simulation issues and solutions
 - Phase coherency
 - Waveform creation
 - Long scenarios
 - Demonstration and summary

Fundamentals of RF Pulse Analysis using a Spectrum Analyzer

Techniques for Radar and EW Signal Simulation
for Receiver Performance Analysis
Copyright 2004, Agilent Technologies



Agilent Technologies

Range: 316.2278 mV

Page 2

Development of today's sophisticated radar systems requires advanced simulation and measurement techniques in order to evaluate performance under all operating modes and to ensure performance specifications are met and fully characterized. In this module radar and EW receivers are addressed, beginning with an overview of their operation and the signal processing performed on the reflected waveform in order to maximize the information extracted from it. Solutions for signal simulation are outlined and demonstrated including new tools and techniques from Agilent.

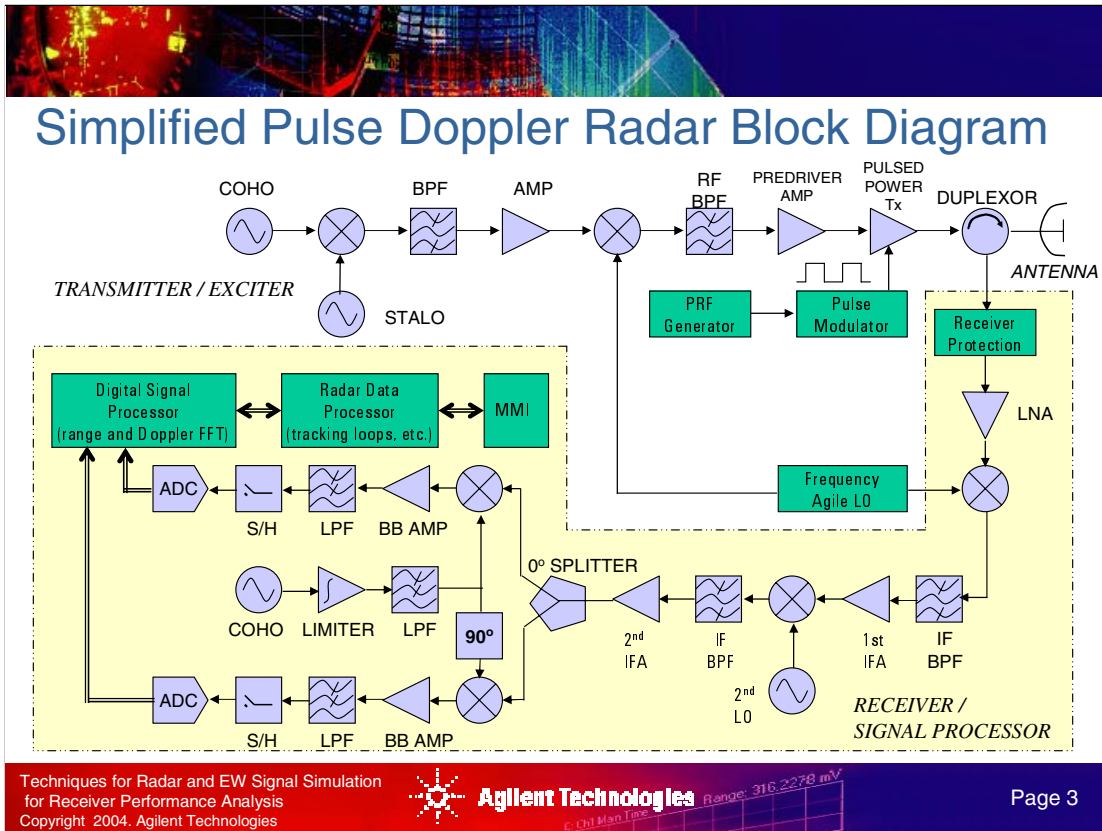

The radar receiver and signal processor are crucial to overall radar system performance. Without adding significant noise of its own, the receiver RF front end must provide sufficient gain to amplify weak returns for subsequent signal processing. To avoid interference from out-of-band spectra, the front end has a clearly specified bandwidth.

Depending on the radar design, one or more RF/IF downconversion stages are present, and must be tested for spurious contribution, dynamic range, compression, and gain/phase response. For a coherent pulse-Doppler radar, the last IF stage feeds a synchronous detector (I/Q) demodulator, which separates signals into their real and imaginary components. This preserves target direction and valuable signal-to-noise ratio. Important measurements here include quadrature error, gain match, image rejection, and two-tone intermodulation distortion.

The ADC converts I and Q baseband signals into digital samples for manipulation. Depending on the particular radar design, the digital signal processor (DSP) will perform some or all of the following functions: pulse compression, pulse integration, sidelobe suppression, Doppler estimation, range estimation, azimuth & elevation estimation, compensation for system errors including quadrature error and gain imbalance and so forth. The radar data processor generally handles the track process, provides the interface to the radar for the operator, and serves as the controller for the radar.

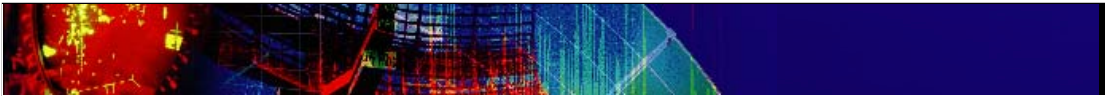

Agenda

- Radar receiver overview

- ➔** System level testing and performance evaluation

- Modes of operation

 - Signal processing considerations

- Signal simulation issues and solutions

 - Phase coherency

 - Waveform creation

 - Long scenarios

- Demonstration and summary

Fundamentals of RF Pulse Analysis using a Spectrum Analyzer

Techniques for Radar and EW Signal Simulation
for Receiver Performance Analysis
Copyright 2004, Agilent Technologies



Agilent Technologies



Page 4

Development of today’s sophisticated radar systems requires advanced simulation and measurement techniques in order to evaluate performance under all operating modes and to ensure performance specifications are met and fully characterized. In this module radar and EW receivers are addressed, beginning with an overview of their operation and the signal processing performed on the reflected waveform in order to maximize the information extracted from it. Solutions for signal simulation are outlined and demonstrated including new tools and techniques from Agilent.

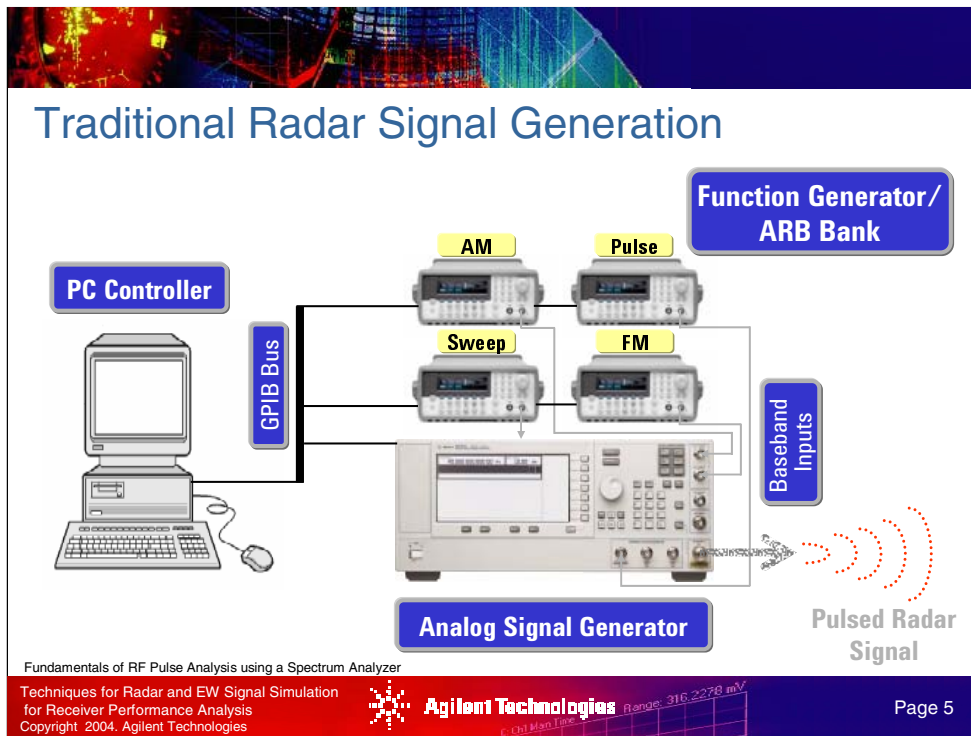

This is a traditional equipment setup for radar signal generation.

Because most radar systems are custom built, signal generators are used in all stages of the design process. Given the broad range of applications, a variety of signal generation solutions have emerged to provide a test stimulus for the employed radar system. These range from home brew solutions based on golden devices to sophisticated signal generation solutions like the obsolete Agilent FASS (frequency agile signal simulator) system.

A typical setup using analog techniques to generate radar test signals is illustrated on the slide. This is a simple system configured using standard test equipment. In this setup, multiple function generators with basic ARB functionality are used to drive the Pulse, AM, FM, and Sweep inputs of an analog microwave signal generator. Using this setup a variety of radar test signals can be generated, ranging from pulsed CW... to shaped pulses using AM... to complex chirps using FM and Sweep. This is adequate for some applications, however the pulse shaping capability is limited and managing the timing relationships associated with pulsing modulated signals can be complicated. A PC is often used to control the instruments over the GPIB bus. Because of the system complexity, there is also a high cost associated with calibrating and maintaining a system like this.

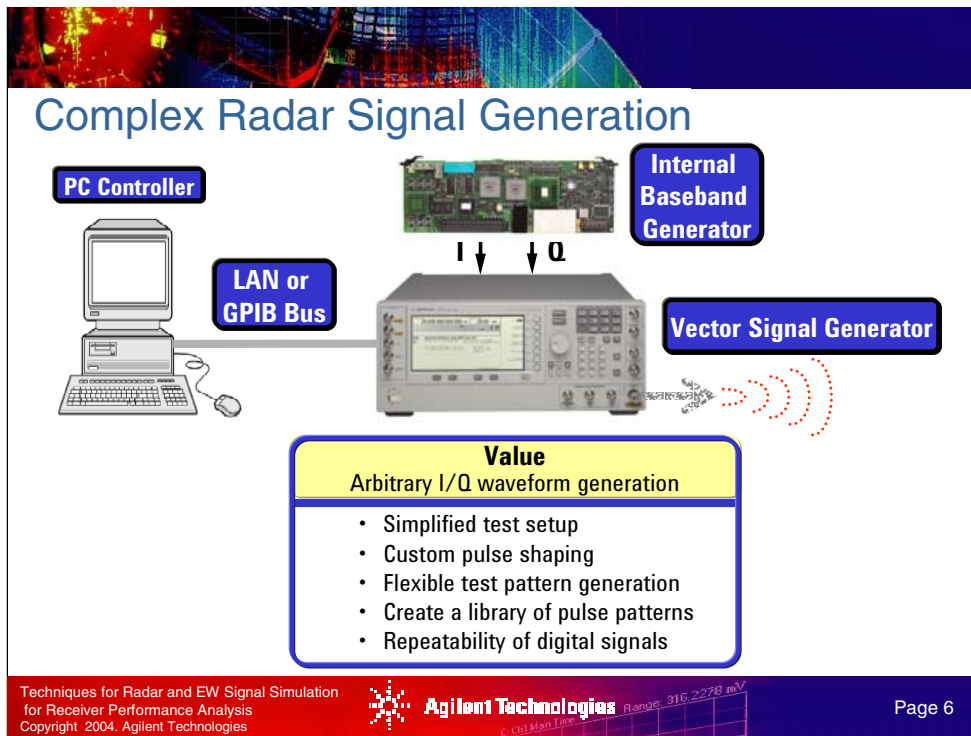

All the features from a traditional radar signal generation setup is now provided in our PSG vector signal generator.

Rather than using traditional analog techniques, the PSG vector signal generator utilizes I/Q modulation to provide flexible radar signal generation, unparalleled in a standard off-the-shelf product.

Now, arbitrary waveforms representing pulsed radar signals can be defined in the time domain using industry standard tools, like MATLAB® or ADS, and played back using the PSG's internal baseband generator. This technique enables custom pulse shaping, accommodates pulse compression, including FM chirp and Barker coding, and eliminates many of the synchronization issues associated with pulsing modulated signals using traditional analog techniques. In addition, the baseband generator's deep playback memory and waveform sequencing capability facilitates the generation of complex radar test patterns.

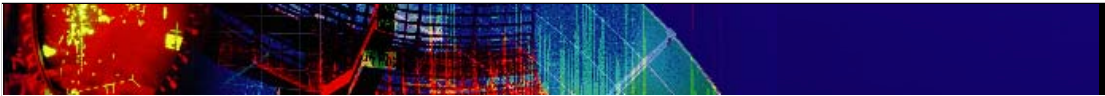

Waveform Simulation

- **Computer modeling of waveforms**
 - Hypothetical signals
 - Helps to identify the optimum radar waveform
 - Theoretical
- **Signal injection of real simulated waveforms**
 - With vector signal generation injection is possible at any hardware interface
 - RF, IF, Baseband, Digital IQ or IF
 - Controlled and repeatable tests of radar operation and signal processing capability
 - Accessible equipment

Fundamentals of RF Pulse Analysis using a Spectrum Analyzer

Techniques for Radar and EW Signal Simulation
for Receiver Performance Analysis
Copyright 2004, Agilent Technologies



Agilent Technologies



Page 7

To the Electronic Warfare (EW) community, radar signal simulation means threat generation for the purpose of testing a receiver’s ability to detect and classify a given emitter. To the radar engineer, radar signal simulation generally implies radar target simulation, including effects of environmental disturbances (clutter) and man-made electronic countermeasures (ECM).

The definition can be further divided to distinguish computer simulation from signal injection simulation. Computer simulation generally precedes hardware development and is used to provide hypothetical models to estimate actual radar performance. This is an important part of any system development and should be viewed as an essential activity before full-scale development begins.

Signal injection allows the radar to be stressed in an electronic environment similar to what will be encountered in the field. This provides for a high degree of repeatability and the flexibility to inject the signal at various points along the signal path to characterize individual sections of the radar or to isolate problem areas.

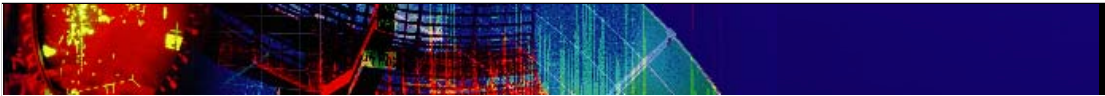

Tests to Specification & Performance Testing

Parametric Tests

- **VSWR, noise figure, bandwidth, sensitivity, gain**
- **System, subsystem, component specifications**
- **Easy to quantify and use for comparison**
- **Indirect indication of field performance**

Functional Performance Tests

- **Subjective check-out of the end-to-end system**
- **How will the system respond to clutter, multipath, jamming & noise**
- **Algorithm performance**
- **Performance under system loading: multiple targets, Doppler, RCS**

Fundamentals of RF Pulse Analysis using a Spectrum Analyzer

Techniques for Radar and EW Signal Simulation
for Receiver Performance Analysis
Copyright 2004, Agilent Technologies



Agilent Technologies

Range: 316.2278 mV

Page 9

Types of tests can be divided into two groups: parametric or specification tests and functional performance tests. Parametric tests include benchmarks such as noise figure, gain, VSWR, intermodulation distortion, and so forth. These values are relatively easy to derive, measure and quantify. They provide important information about individual circuit modules and are useful in comparing and evaluating different or evolving designs.

These parameters alone provide no guarantee that the radar or EW system will operate as expected, given a real target or hostile environment scenario. So, more rigorous evaluation methods are needed for characterizing the end-to-end system performance. These methods can answer questions such as: “How many targets can be tracked?”, “How will maneuvering targets be handled?”, How will the system react to different types jamming like velocity gate stealing¹, or a RF barrage?”, or “What is the probability of detection in a clutter environment?”.

¹See “ECM” on page 15

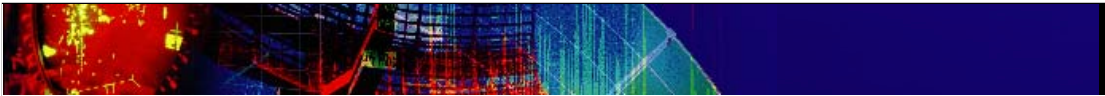

Functional Performance Test Alternatives

<u>Measurement Option</u>	<u>Considerations</u>
Battlefield operational testing	Situation dependent, high risk, real operational conditions
Flight/field testing	Very expensive, some environmental control
Custom environment simulators	High repeatability, high development costs, customized
Off-the-shelf signal simulator	Affordable, reconfigurable, moderate realism

The most realistic way to test a radar is during and actual engagement. Operational performance during actual warfare immediately brings to light system issues but there are limitations. For instance the system is not fully instrumented when fielded and often the data needed for proper evaluation is not available. Testing also becomes situation dependent, making it difficult to reproduce a given scenario for system characterization.

Other alternatives include flight testing. The high cost of crew, support personnel, jet fuel and the hardware itself limits the amount of testing that can be readily accomplished in the air.

Other techniques include expensive custom simulator solutions. These are useful during the entire system development cycle but are high in cost and often require a project team onto itself to develop.

The most affordable approach that provides versatile and realistic signals is an off-the-shelf vector signal generator.

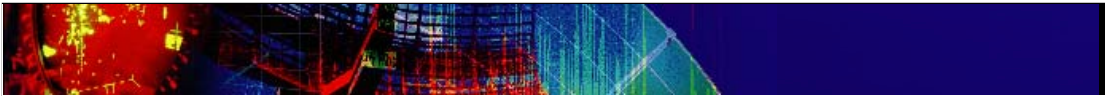

Agenda

- Radar receiver overview
- System level testing and performance evaluation
- ➔ Modes of operation
 - Signal processing considerations
- Signal simulation issues and solutions
 - Phase coherency
 - Waveform creation
 - Long scenarios
- Demonstration and summary

Development of today’s sophisticated radar systems requires advanced simulation and measurement techniques in order to evaluate performance under all operating modes and to ensure performance specifications are met and fully characterized. In this module radar and EW receivers are addressed, beginning with an overview of their operation and the signal processing performed on the reflected waveform in order to maximize the information extracted from it. Solutions for signal simulation are outlined and demonstrated including new tools and techniques from Agilent.

Radar Modes of Operation

- Search
- Track
- Track-while-Scan
- Fire Control

Airborne Radars

- Ground Mapping
- Air-to-Ground Ordnance Delivery

Long Range Detection

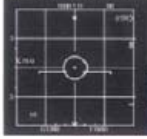





Clean Scope or Clutter Free — Look Down





Automatic Acquisition — Close in Combat





Fundamentals of RF Pulse Analysis using a Spectrum Analyzer

Techniques for Radar and EW Signal Simulation for Receiver Performance Analysis
Copyright 2004, Agilent Technologies

Agilent Technologies

Range: 316.2278 mV
© 2004 Agilent Technologies

Page 12

In the past, any specific radar system may have performed only limited functions. The mode of operation may have involved only searching for, and detecting, new targets. Another, complementary system may have been dedicated to tracking a single target or multiple ones. To overcome the physical constraints of multiple systems (size, power consumption, etc.) and by virtue of programmable control of the entire system (most notably the DSP), modern radar systems are multi-mode, integrating all the necessary functions into one set of hardware.

The graphics above, borrowed from an old APG-63 radar (F-15) brochure, show some of the modes of operation required for an airborne radar system. For this system all needed radar functionality must be performed by a single set of hardware.

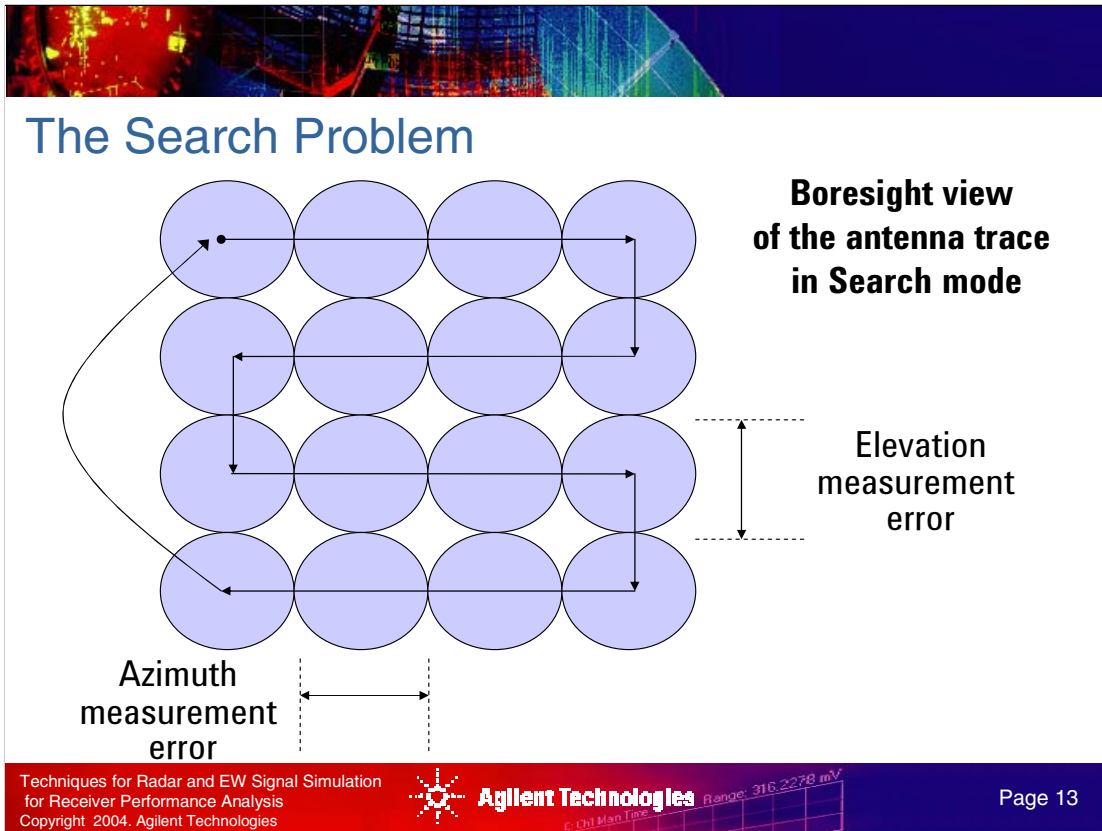

Being able to accurately discriminate the position of a target while continually scanning the sky for new ones is problematic. The target detected in a search mode can be located anywhere within a volume bounded by the beam of the radar and the possible movement of the target between subsequent detections. There is not enough information because of the limited time on target to maintain a track on the target of any utility.

Track-While-Scan systems trade off search capability to illuminate targets more often in an effort to track them with reasonable success.

Other Considerations

Today's military targets effectively reduce their observability by applying new material technologies as well as employing concealment and deception to inhibit acquisition. Consequently, radar systems employing sophisticated signal processing must keep up with the new scenarios through thorough extraction of all usable information about target features gained by precision measurements. The digital signal processor and subsequent radar data processing must interpret the radar signature data for extraction of maximum information from radar returns. Target and clutter data are then used to perform surveillance, detection, discrimination, and non-cooperative target identification functions.

The Tracking Problem

Conical Scan Tracking

Monopulse Tracking

Fundamentals of RF Pulse Analysis using a Spectrum Analyzer
 Techniques for Radar and EW Signal Simulation for Receiver Performance Analysis
 Copyright 2004, Agilent Technologies

Agilent Technologies Range: 316.2278 mV

Page 14

In order to determine where in the beam volume the target actually is, a technique is needed to gain additional resolution. Better range accuracy is obtained by using the pulse edges as a measure of target range or pulse compression² methods. Better angle information is obtained by probing the space in a tight conical scan or by simultaneously generating two adjacent beams, referred to as monopulse tracking. Conical scanning has the drawback that as the beam angle changes so may the position or orientation of the target.

Once a target has been acquired, a data structure of position and velocity information is accumulated from the radar return information. This information feeds a tracking algorithm driven by a mathematical construct known as the Kalman filter.

The Kalman filter is a set of mathematical equations that provides an efficient computational (recursive) means to estimate the state of a process, in a way that minimizes the mean of the squared error. The filter is very powerful in several aspects: it supports estimations of past, present, and even future states, and it can do so even when the precise nature of the modeled system is unknown.

The purpose of a Kalman filter in radar target tracking is to estimate the state of a system from measurements which contain random errors. There are 3 components of position and 3 of velocity so there are at least 6 variables to estimate. These variables are called state variables. With 6 state variables the resulting Kalman filter is called a 6 dimensional Kalman filter.

²See more about pulse compression on page 29

Tracking Maneuvering Targets

Acceleration component must be estimated from previous velocity and position information

Rapid changes in radial acceleration may cause tracking algorithm to break lock

Where the #*%@! did he go ?!!

Fundamentals of RF Pulse Analysis using a Spectrum Analyzer
 Techniques for Radar and EW Signal Simulation for Receiver Performance Analysis
 Copyright 2004, Agilent Technologies

Agilent Technologies Range: 316.2278 mV
 Page 15

Using radar to track maneuvering targets is a complex problem since it does not directly measure acceleration. The radar system estimates acceleration from the position (range and angle) and velocity measurements it makes. The velocity information is radial only, along the line that extends from the radar to the target.

Rapid changes in acceleration can bring about large errors in the estimates of the tracking algorithm and cause the radar to break lock.

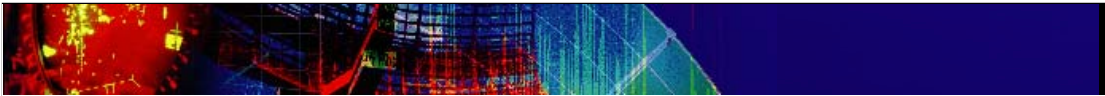

Agenda

- Radar receiver overview
- System level testing and performance evaluation
- Modes of operation
 - Signal processing considerations
- Signal simulation issues and solutions**
 - Phase coherency
 - Waveform creation
 - Long scenarios
- Demonstration and summary

Development of today’s sophisticated radar systems requires advanced simulation and measurement techniques in order to evaluate performance under all operating modes and to ensure performance specifications are met and fully characterized. In this module radar and EW receivers are addressed, beginning with an overview of their operation and the signal processing performed on the reflected waveform in order to maximize the information extracted from it. Solutions for signal simulation are outlined and demonstrated including new tools and techniques from Agilent.

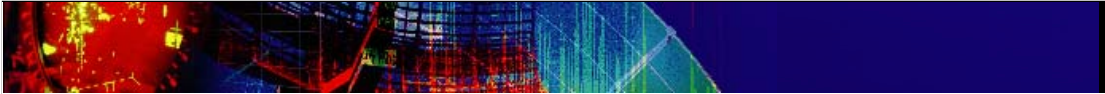

Phase coherency issues: source - receiver & source - source

Fundamentals of RF Pulse Analysis using a Spectrum Analyzer

Techniques for Radar and EW Signal Simulation
for Receiver Performance Analysis
Copyright 2004, Agilent Technologies



Agilent Technologies

Range: 316.2278 mV
C:\cd\Hao\Tape

Page 17

Radar Target Signal Simulation

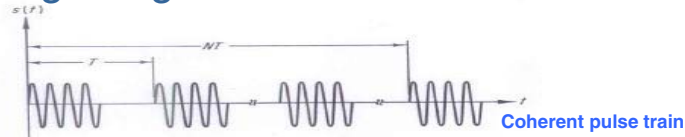

- **Simulating multiple and realistic targets is essential in the development and verification of radar receivers**
- **Simulation systems for use with active and coherent radar systems are currently almost always based on digital RF memories (DRFM)**
- **Passive or bistatic/multistatic radars, and those active systems that use incoherent detection methods, can benefit from simulation tools based on commercial off-the-shelf (COTS) vector (I/Q) arbitrary waveform generators (ARB)**
 - Lower cost
 - Greater flexibility
 - Deep memory waveform playback



Fundamentals of RF Pulse Analysis using a Spectrum Analyzer

Techniques for Radar and EW Signal Simulation
for Receiver Performance Analysis
Copyright 2004, Agilent Technologies



Agilent Technologies

Range: 316.2278 mV

Page 18

Radar return signal simulators are capable of simulating a maneuvering target by varying the relative phase of I and Q channel baseband input signals, the speed of the target by adjusting the baseband input frequency and the size and/or distance of the target by adjusting the signal strength.

Development of radar receivers for real-world target detection involves modeling of return pulse trains that vary in terms of range, doppler, and aspect angle. When a radar target consists of many reflecting surfaces offset from each other, the amplitude and phase of the return pulses are dependent on the orientation of the target. If the target has motion with respect to the radar receiver like yaw, pitch or tumble the radar cross section will vary as a function of time. These fluctuations are characterized as either slow (change from scan to scan) or fast (change from pulse to pulse).

Although currently DRFM technology is most often used in target simulation for active radars because of the ability to maintain phase coherence with the radar transmitter, off-the-shelf arbitrary waveform generators will soon be able to address this application at a much lower cost.

An arbitrary waveform generator with deep memory capability can be effectively used to test passive or bistatic radar receivers such as missile seekers.

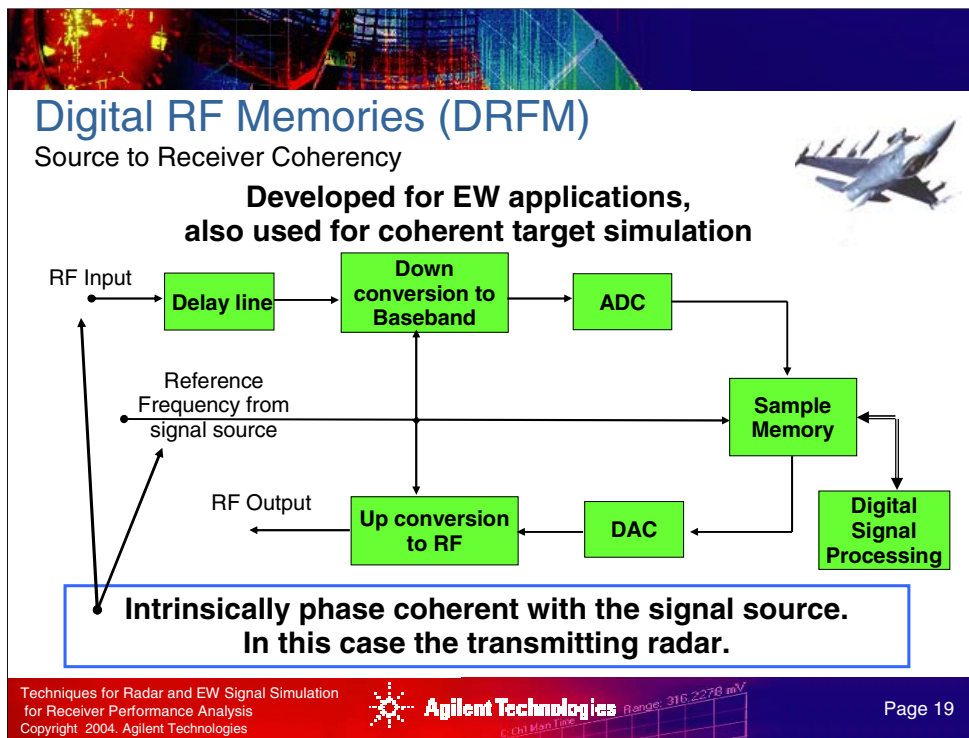

The most widely used method of target simulation is to employ a DRFM (duration) or digital RF memory. The DRFM allows the indefinite storage (delay) of radio frequency signals in digital form. Signals can be played back in exact replication of the original coherent signal or with the signal altered for the user's purpose.

Signal dynamic range of currently available units are generally limited to 8-bits due to memory write speed limitations.

Instantaneous BW can be up to several hundred MHz but cost increases exponentially.

ECM

DRFM technology was initially used in electronic counter measure (ECM) as a jammer for radar signals. By gradually increasing the time between when the signal is received and when it is reproduced and transmitted back results in range gate stealing where the tracking radar is led away by the jammer in terms of range before the signal is abruptly turned off. In the same way, the phase of the returned coherent pulse train can be altered to provide velocity gate stealing. These false signals are returned to the transmitting radar at a higher amplitude than the actual return causing the AGC of the receiver to be set such that the true signal is attenuated below detection level.

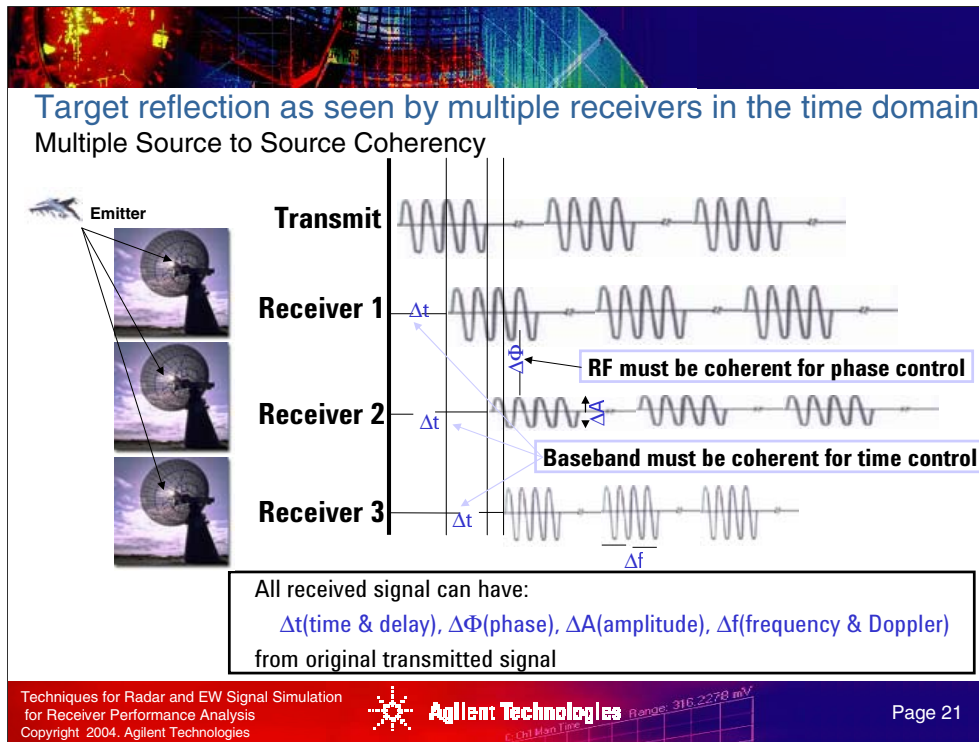

A signal is transmitted or reflected from one location. Since each of the receivers are at a different location, they see the signal differently. Each of the receivers see the signal with a different time, phase, amplitude and frequency than the others. To be able to accurately simulate this signal, you need complete control of those parameter for multiple signal generators.

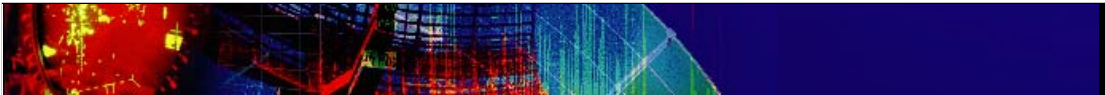

Geo-Location Application

Interferometric Synthetic Aperture Radar (InSAR)

When testing the receiver, input signals to each antenna must be phase Coherent.

Used in monitoring the effects of earthquakes & floods, land subsidence, glaciers, crop sizes, military targeting, etc.

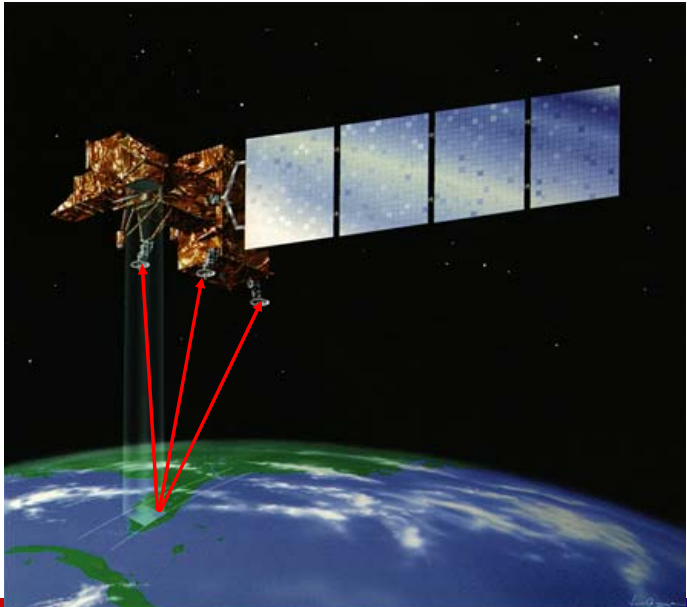

Techniques for Radar and EW Signal Simulation for Receiver Performance Analysis
Copyright 2004, Agilent Technologies



Agilent Technologies Range: 316.2278 m

Page 22

The Geo-Location application requires simulation of several radar reflections that are phase coherent with one another. The multiple receivers in the system use the phase relationships between the returns to enable precision mapping and location information. This resolution is generally measured in millimeters.

InSAR

Characterization of the way in which the surface of the earth deforms in response to internal and external forces relies on a variety of geodetic measurement techniques. Most of these methods provide point-to-point measurements of the displacement field. In contrast, Interferometric Synthetic Aperture Radar (InSAR) provides two-dimensional map views of the deformation.

InSAR relies on repeated imaging of a given geographic location by air or space-borne radar platforms. With two or more complex (magnitude and phase) radar images of the same area one can construct an interferogram as the difference in phase of the return from each pixel. The phase differences are sensitive to topography and any intrinsic change in position of a given ground reflector. These two effects can be separated using either an independent topographic data set or an additional interferogram that does not include any surface deformation, i.e., with negligible temporal separation between acquisitions. The final product is a map view of the component of surface motion in the direction of the sensor, i.e., the line-of-sight (LOS) displacement. Interferograms typically have 20 to 80 meter pixel sizes and can detect displacements of a few millimeters. *[Center for Advanced Computing Research, Cal Tech]*

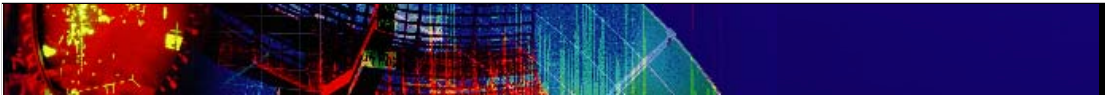

Phased Array Antenna

Returns incident on different T/R modules of the array are not parallel and have relative phase differences that contain target position information

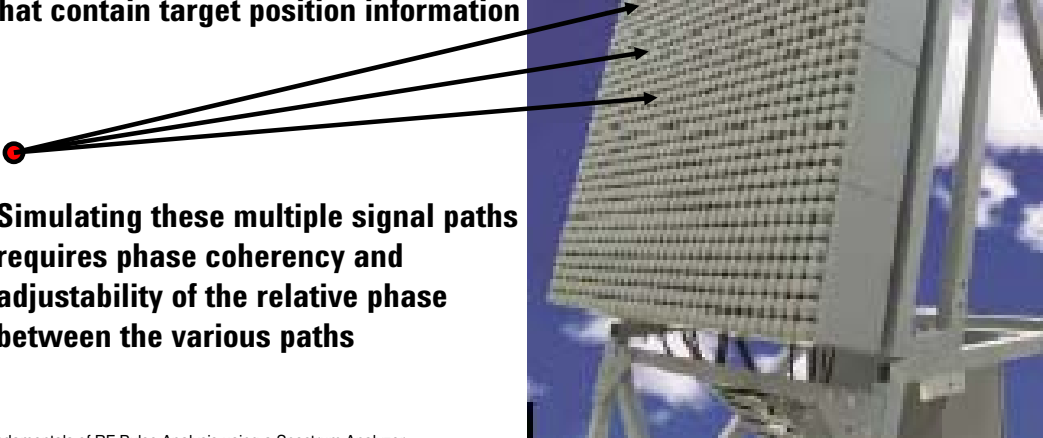

Simulating these multiple signal paths requires phase coherency and adjustability of the relative phase between the various paths

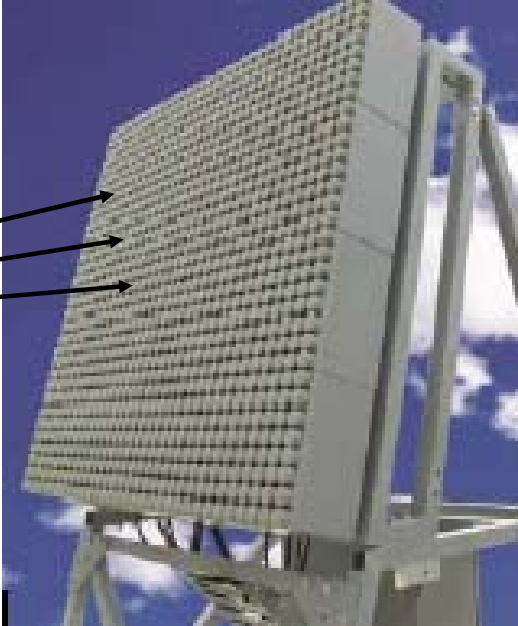

Fundamentals of RF Pulse Analysis using a Spectrum Analyzer

Techniques for Radar and EW Signal Simulation for Receiver Performance Analysis
Copyright 2004, Agilent Technologies



Agilent Technologies

Range: 316.2278 mV

Page 23

A phased array antenna is composed of lots of radiating elements each with the ability to shift the phase of its transmitted signal. Beams are formed by shifting the phase of the signal emitted from each Tx/Rx module, to provide constructive and destructive interference in order to steer the beams in a particular direction.

Simulating the received signal requires that the input to each Tx/Rx module be phase coherent each other with a known phase relationship. They must be independently adjustable in time, phase, and amplitude.

RF Phase Coherency: Multiple Outputs at Same Frequency Using RF Split Technique

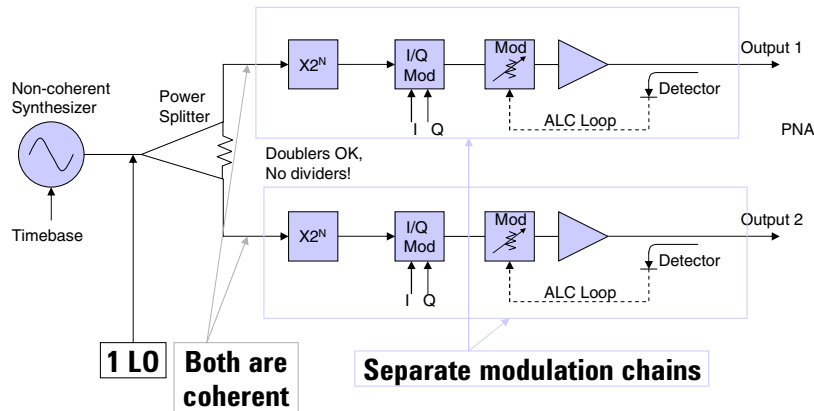

Fundamentals of RF Pulse Analysis using a Spectrum Analyzer

Techniques for Radar and EW Signal Simulation
for Receiver Performance Analysis
Copyright 2004, Agilent Technologies



Agilent Technologies

Range: 316.2278 mV

Page 24

Here is a block diagram of signal sources in a configuration to support phase coherency between the sources. To solve the drift issue associated with multiple local oscillators we have devised a scheme of using 1 local oscillator and distributing it to multiple sources. After the LO distribution, each signal generator will have their own modulation chain. This is required to simulate the applications we just spoke about.

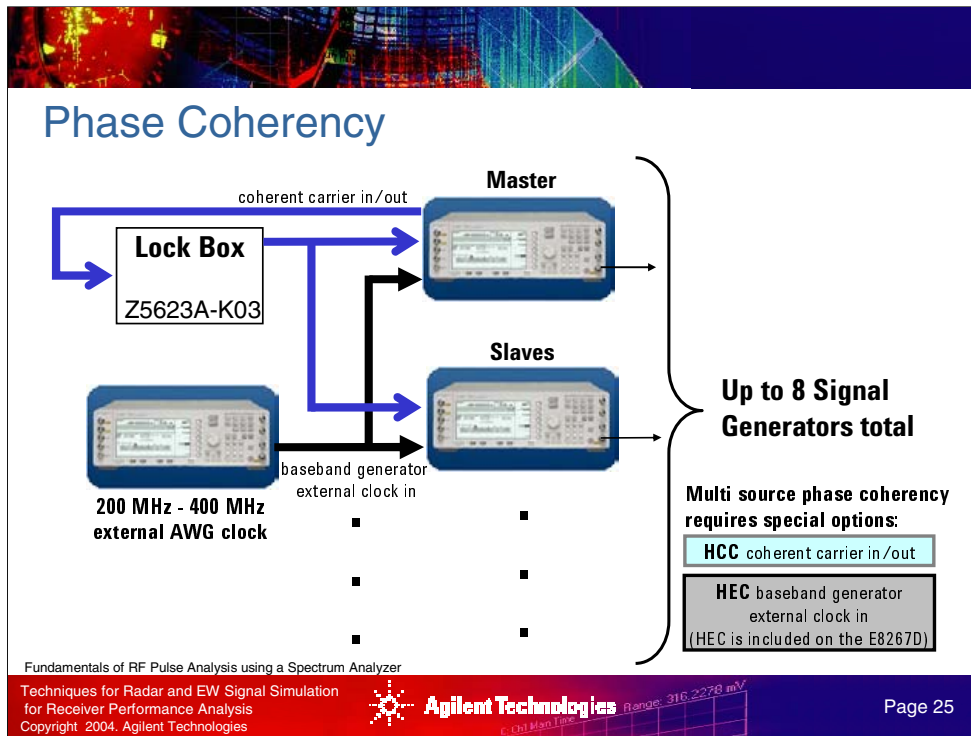

Phase coherency on the ESG and PSG is now available. In order to achieve phase coherency, three options are required: -HEC, -HCC, and Z5623A-K03.

-HCC: Provides coherent carrier in/out from 250 MHz to 4 GHz. The coherent carrier out from the master is fed to the Z5623A-K03 “lock box”.

Z5623A-K03/K05: Splits and amplifies the input signal up to 8 ways. The output of the lock box is fed to the coherent inputs of the master and slaves. This will yield carrier coherency from 250 MHz to 20 GHz.

-HEC: Sends a common clock signal (not clock reference) to drive the master and slaves’ baseband generators. The clock rate must be between 200 MHz and 400 MHz, or else each baseband generator will treat the input as a clock reference and upsample it.

Result:

- Outputs will be phase coherent
- Outputs will have a fixed phase offset
- Phase offset can be introduced or corrected with phase shift in I/Q waveform

Note:

- If power is changed in either box, the phase offset will change
- Temperature will also affect the phase of both boxes

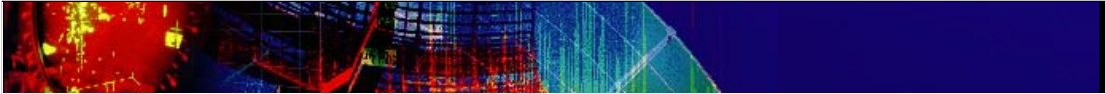

Waveform creation for radar signal returns

Fundamentals of RF Pulse Analysis using a Spectrum Analyzer

Techniques for Radar and EW Signal Simulation
for Receiver Performance Analysis
Copyright 2004, Agilent Technologies



Agilent Technologies

Range: 316.2278 mV
C:\cd\Hao\Tape

Page 26

Radar Cross Section (RCS)

- The amplitude and phase of the radar return signal changes as the aspect angle of the target changes
- RCS is very dependent of the target size, shape and construction material
- Radar return RCS simulated using Swerling models (I – IV)

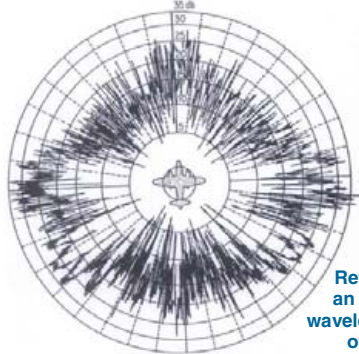

Return power from an aircraft at 10 cm wavelength as a function of azimuth angle

In order to evaluate the radar performance in terms of ability to find and track various target types as they maneuver, many different long scenarios are required.

Techniques for Radar and EW Signal Simulation for Receiver Performance Analysis
Copyright 2004, Agilent Technologies



Agilent Technologies

Range: 316.2278 mV

Page 27

The radar cross section (RCS) of a target is a measure of a targets reflectivity in a given direction. The main contributors to RCS are:

- Specular scattering – localized scattering dependent on the surface material/texture
- Diffraction scattering – incident signal scattering at target edges and discontinuities
- Multiple bounce – reflections among target elements at offset angles

The objective in modeling RCS is to develop simulation tools capable of predicting the behavior of radar receivers in a realistic environment.

As an interesting note, radar cross section (RCS) helicopter simulations are at least a thousand times more time consuming than those for fixed-wing aircraft, partly because the rotating blades, both the main rotor and the tail rotor, must be modeled in thousands of positions.

The Swerling models described below is one simple set of models among many used to simulate the RCS of various types of targets.

Swerling I – The amplitude of the return pulses is a random variable with a Rayleigh probability distribution and the phase is an independent random variable with a uniform probability distribution.

Swerling II – Same as Swerling I except the amplitude of each pulse is an independent random variable.

Swerling III – Similar to Swerling I (each pulse has the same amplitude) but the amplitude has one particular value that is dominant in the probability distribution (one dominant plus Rayleigh distribution).

Swerling IV – Similar to Swerling II (each pulse amplitude is independent) but each pulse amplitude has one particular value that is dominant in its probability distribution (one dominant plus Rayleigh distribution).

Radar Emitter Simulation & ELINT Receiver Test

- Radar emitter simulation can also be characterized as “Radar Threat Simulation”
- Most current systems are combinations of off the shelf equipment and custom hardware
- Electronic and signal intelligence systems must be evaluated with signals that match the complexity of current operational communication systems
- Testing human interaction with electronic threats requires a realistic simulation environment

Fundamentals of RF Pulse Analysis using a Spectrum Analyzer
 Techniques for Radar and EW Signal Simulation for Receiver Performance Analysis
 Copyright 2004, Agilent Technologies

Agilent Technologies Range: 310.2278 mV
 0.01 Max [dB]

Page 28

The requirements of a radar emitter simulator are to simulate various types of radar emitters or to simulate the multiple modes of operation for a single type of radar.

ELINT (Electronic Intelligence) and SIGINT (Signal Intelligence) receivers are not limited to radar applications. Some are designed to scan for communication signals and track frequency agile systems then monitor for certain signal characteristics and output the signals content (text, voice etc.). Creating test scenarios for these systems requires deep memory waveforms to provide long and unique signal patterns whether emulating communications or radar signals

EW threat emitter simulations are used to:

- Train military aircrews in the recognition of mobile tactical threats.
- Provide aircrews with a more realistic training range environment.
- Provide active threat radar parametrics for airborne and missile systems signal stimulation for national sensors and data analysis.
- Provide signal stimulation for antimissile radiation testing.

Signal Studio for pulse building

Features

- Easily navigate the intuitive user interface
- Create a pulse and pulse pattern libraries
 - Construct custom pulse shapes
 - Apply intra-pulse modulation
- Wide bandwidth (up to 800 MHz) capability
- Apply baseband pre-distortion
 - Improve image rejection
 - Optimize RF modulation flatness
- Automate using the COM-based API
- Utilize extensive built-in Help

Value

- Set high-level pulse parameters
- Eliminate complicated mathematics
- Simplify single-emitter test pattern generation
- Enhance signal quality

LAN/GPIB Bus

Pulse Building

PSG or ESG

PSA or ESA

Techniques for Radar and EW Signal Simulation for Receiver Performance Analysis
Copyright 2004, Agilent Technologies

Agilent Technologies Range: 316.2278 mV

Page 29

For many common pulse or radar applications Agilent’s Signal Studio for pulse building software eliminates the need to write custom software programs. It provides a graphical user interface (GUI) that makes it easy to create complex pulsed signals without detailed knowledge of the math required to calculate the signals. It also provides simple CW pulses with shaping and complex phase and frequency-encoded signals. The user can easily build pulses and pulse patterns to simulate complex emitters. Once created, the signals can be saved on the signal generator’s internal hard disk drive and recalled later without an external PC or software. This software may be used with either an ESG or PSG vector signal generator.

To simplify this testing more we are offering a Signal Studio application targeted at single-emitter radar test pattern generation. Utilizing this application, the mathematics required to calculate the I/Q waveform samples will be transparent to the user. By simply setting a few high-level pulse parameters... like rise time, ramp profile, intra-pulse modulation, etc.... even the novice user can create complex radar pulses. The software will also simplify test pattern generation by providing an interface to setup custom pulse sequences.

When combined with an Agilent ESA or PSA spectrum analyzer, the Signal Studio for pulse building software applies pre-distortion to the calculated waveform to improve image rejection and RF flatness. The spectrum analyzer is required to gather the calibration data need to determine correct pre-distortion coefficients. This process is fully automated by the software. Corrections can also be applied to custom I/Q user data that has been imported to the software.

Linear FM Chirp

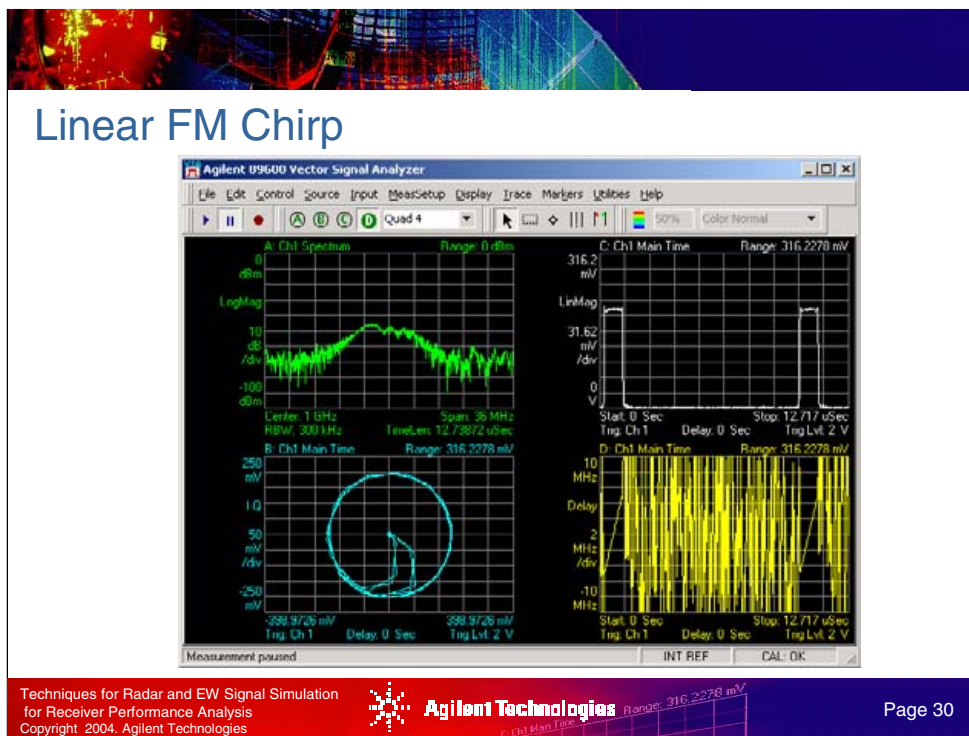

Techniques for Radar and EW Signal Simulation
for Receiver Performance Analysis
Copyright 2004, Agilent Technologies



Agilent Technologies

Page 30

This is a screen capture from the 89600 Vector Signal Analyzer to analyze a linear FM chirp signal.

The upper left hand plot shows the frequency spectrum of the signal. The upper right hand plot shows the linear amplitude time domain waveform. The lower left hand plot shows the IQ vector for the signal. The lower right hand plot displays the phase of the signal versus time. Observe linear amplitude plot and note that the amplitude of the signal is constant within a single pulse and between pulses. From the phase plot versus time; note that the phase of the pulse is constant within a single pulse and between pulses. This infers that the PSG vector signal generator is coherent in frequency and phase with the Vector Signal Analyzer.

Note the demodulated fm waveform in the lower right hand plot. The chirp is linear and the deviation is equal to the 10 MHz defined in the program (± 5 MHz). The values in the fm demodulator are only defined during the on-time of the pulse. In the upper right hand plot, note that the amplitude of the pulse is flat during the pulse on-time. Because the signal is being swept across a 10MHz frequency span, this indicates the IQ modulator within the signal generator provides a flat frequency response across that bandwidth. The spiral effect in the IQ plot in the lower left hand corner is due to the frequency offset from the carrier during the rise and fall time of the pulse.

N7622A Signal Studio toolkit

1) Waveform download utility for custom I/Q waveforms (No Charge)

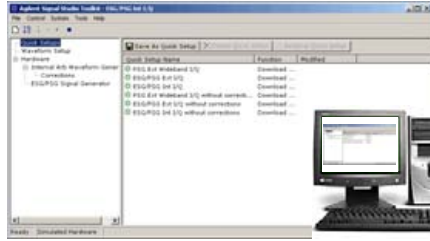

Available
October '04

PSG Narrowband configuration
E8267D w/option 601 or 602

PSG Wideband configuration
E8267D w/option 015 wideband IQ
(3.2 to 44 GHz)

2) Optional linear corrections

- Improve image rejection, amplitude flatness, and group delay for your custom waveforms
- Two different bandwidth options
 - » Narrow bandwidth (80 MHz modulation BW) \$4K
 - » Wide bandwidth (800 MHz modulation BW) \$9K
- Requires a PSA spectrum analyzer

LAN/GPIB

RF out

I/Q

Tektronix AWG520
(AWG520 only required for wideband configuration)

PSA series
spectrum analyzer

Fundamentals of RF Pulse Analysis using a Spectrum Analyzer

Techniques for Radar and EW Signal Simulation
for Receiver Performance Analysis
Copyright 2004, Agilent Technologies



Agilent Technologies

Page 31

The new Signal Studio toolkit software enables you to easily download your custom I/Q waveforms. This functionality is free. Additionally, an Optional linear correction feature may applied to your custom waveform to improve the image rejection, amplitude flatness and group delay for your custom waveforms. There will be two different correction bandwidth options offered. This functionality will require the PSA series spectrum analyzer. The first correction bandwidth option applies corrections across 80 MHz and works with the PSG's internal baseband generators. The narrow bandwidth option will be priced around \$5000 USD. The second bandwidth option works with the AWG520 Tek arb and will correct across 800 MHz bandwidth and will be priced around \$10000 USD.

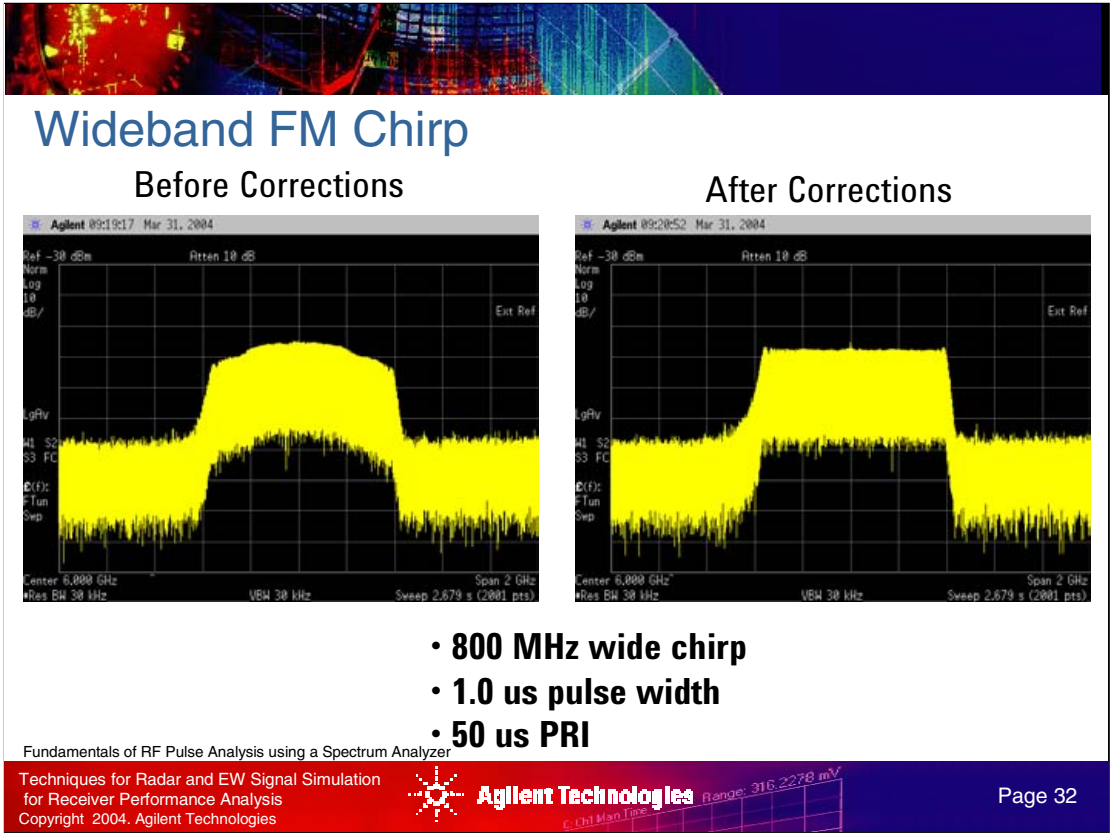

Here is an example that illustrates RF amplitude flatness before and after predistortion for a FM chirp signal. The signal occupies 800 MHz RF bandwidth. A scale of 10 dB per division is used. As shown, with proper conditioning the flatness can be improved even over very wide bandwidths using advanced predistortion techniques.

The FM chirp modulation is a form of pulse compression or modulation within the radar pulse that will provide additional information on the return signal to improve resolution. The radar range equation points out a basic engineering trade-off between range and resolution and the need for pulse compression. To build a long range radar (or for the radar to 'see' a great distance) the radar needs high average output power. To obtain good resolution, the radar needs a narrow pulse that reduces the average output power. Pulse compression provides a path around this trade-off. Pulse compression radars will transmit a long pulse with modulation inside the pulse. The returns are processed through a filter that is matched to the characteristics of the modulation compressing the pulse in time. This compression allows the radar to separate overlapping returns while transmitting a high average power.

It is important for ELINT and radar warning receivers to correctly process these types of signals. The modulation type and deviation of the signals provide important information about the purpose and intent of an observed system. It is often difficult to obtain a signal source with the appropriate characteristics to verify the performance of the ELINT system.

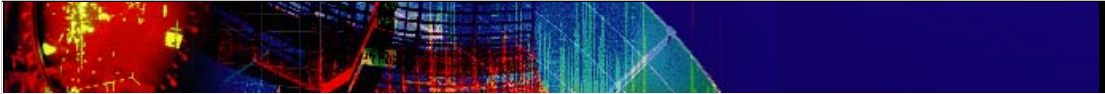

Simulation of long waveform scenarios

Fundamentals of RF Pulse Analysis using a Spectrum Analyzer

Techniques for Radar and EW Signal Simulation
for Receiver Performance Analysis
Copyright 2004, Agilent Technologies



Agilent Technologies

Range: 316.2278 mV
C:\cd\Hao\Tape

Page 33

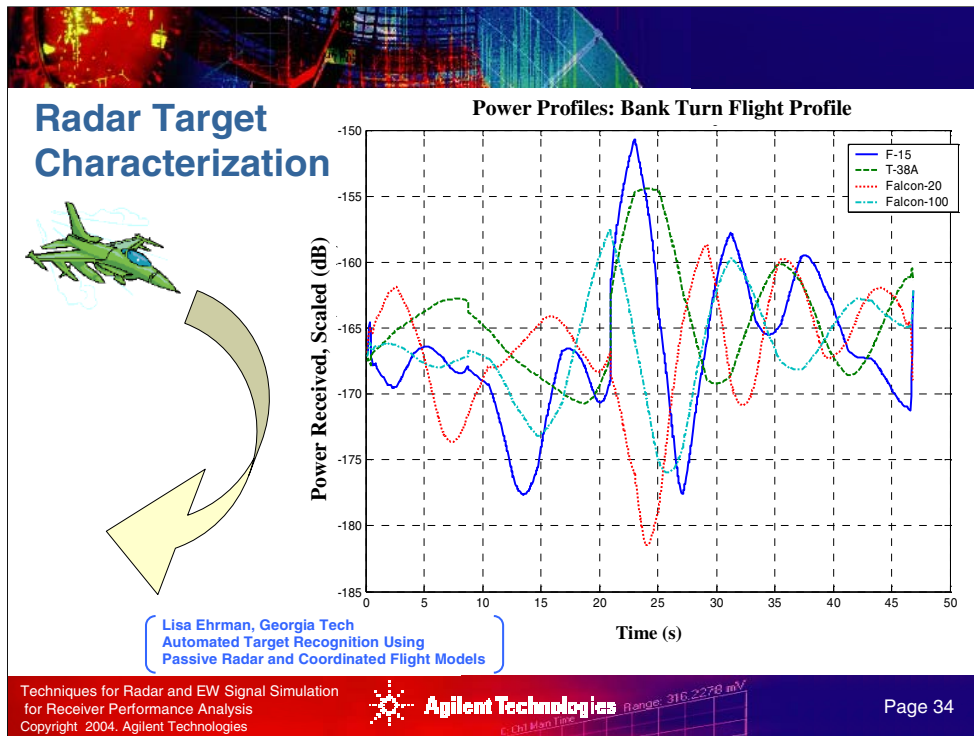

This chart indicates the power of the signal incident to the antenna of a passive radar for various types of aircraft. In this application, the radar and subsequent signal processing is trying to determine the aircraft type from certain characteristics of the RCS. Note the time required (47 seconds) to model or simulate a simple maneuver such as banked turn.

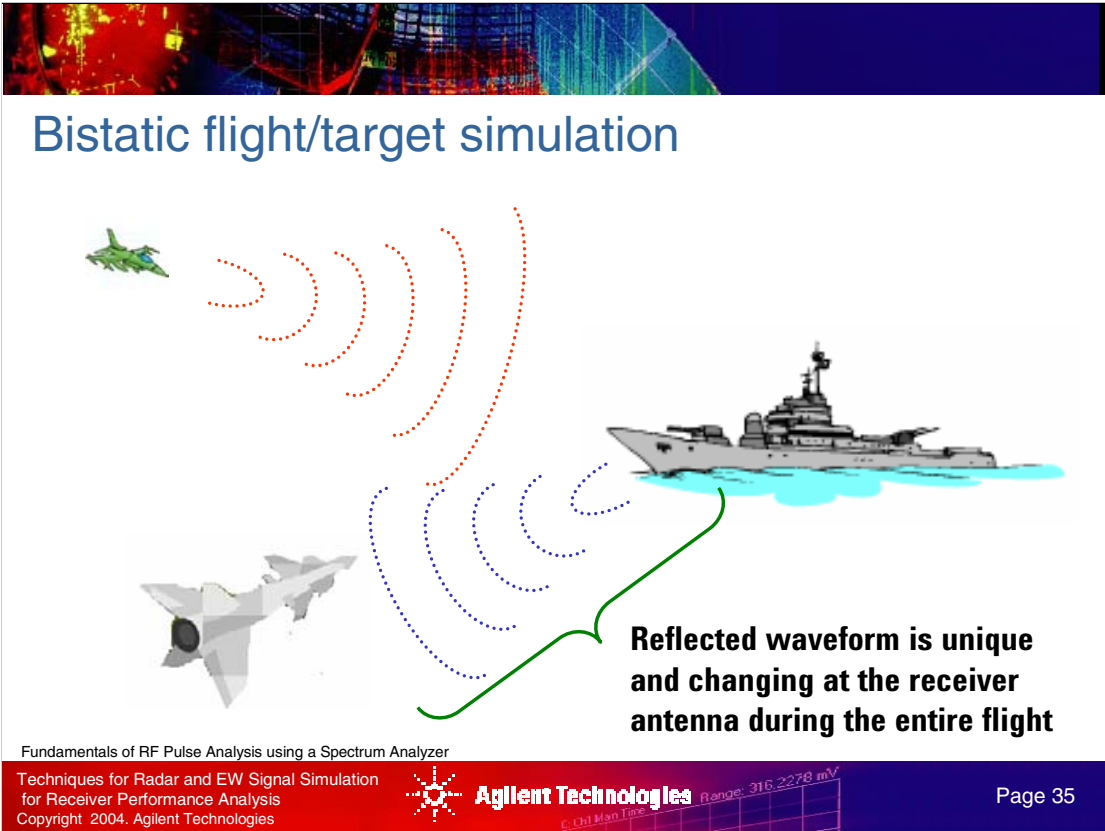

The diagram illustrates a bistatic radar simulation. A green fighter jet is shown in flight, emitting red dotted wavefronts. A grey fighter jet is shown below it. A large grey ship is on the right, with blue dotted wavefronts reflecting off its surface. A green arrow points from the ship to a text box.

Bistatic flight/target simulation

Reflected waveform is unique and changing at the receiver antenna during the entire flight

Fundamentals of RF Pulse Analysis using a Spectrum Analyzer
Techniques for Radar and EW Signal Simulation for Receiver Performance Analysis
Copyright 2004, Agilent Technologies

Agilent Technologies Range: 316.2278 mV

Page 35

Scenarios requiring long and unique waveforms are very common. In this case modeling the signal input to the radar receiver of a radar guided missile or a HARM (High-speed Anti-Radiation Missile). A HARM is a missile guided by the emissions of an threat radar or communication system.

What are Deep Memory Waveforms?

- **Regenerate waveforms directly from I/Q samples stored in a virtually unlimited memory source (e.g. hard disk drive)**
- **Some signal generation applications require long, unique, non-repetitive waveforms**
 - Record and replay of field and flight testing
 - Emitter and target simulation of specific scenarios in the lab
- **The cost of characterizing and testing systems in the field has increased while the budgets allocated for this work have decreased**

Example: The cost of a radar flight test involving two aircraft at Edwards AFB in 1980 was ~\$40K/hour, now the cost is in excess of \$100K/hour

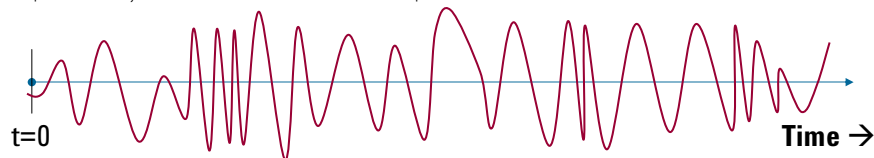

Techniques for Radar and EW Signal Simulation
for Receiver Performance Analysis
Copyright 2004, Agilent Technologies



Agilent Technologies

Range: 316.2278 mV

Page 36

Current waveform generation solutions are inadequate for deep memory applications.

Existing solutions to this problem all have shortcomings. One option is to separate the extremely long non-repetitive signal files into shorter segments that fit in the memory space of the signal generator, and then load and play back each segment one by one. This is not practical for most deep-memory applications, which require waveforms to be continuous. Even if playing signal files in segments is an option, doing so increases test time and complexity. Shortcuts are often taken by cutting back on the number of segments played, reducing test thoroughness and accuracy.

Another alternative is field testing, taking the device to be tested into its working environment to evaluate its performance. This option is costly and inconvenient. Flight test-range costs are hundreds of thousands of dollars per hour. In addition, design iterations can be delayed while logistical issues, such as scheduling, are resolved or while data is sent back to the lab. Another issue with flight test is that the repeatability of measurements is difficult if not impossible.

A third option is to build an in-house custom system to input long waveform files into a signal generator. This is very time consuming to implement, and its cost and accuracy depends on the skill and experience of the engineers tasked to create it.

So engineers are looking for a complete test solution that can cut the time and cost associated with the existing test alternatives.



How Much Memory is Enough?

- **Current off the shelf baseband generators have limited playback and storage memory**
- **Agilent ESG and PSG vector signal generators have up to 64 MSa of waveform memory with the internal baseband generator**
 - At 100 MSa/s this is 640ms of playback time
 - At 40 MSa/s this is 1.6s of playback time
- **Sequencing: solution for waveforms with repetitive segments**
 - Pulsed signals with long periods of “off” time
 - Communications signals with repetitive frames of data
- **Data generated in “real-time” internal to the baseband generator**
 - Currently limited to PN sequences

Fundamentals of RF Pulse Analysis using a Spectrum Analyzer

Techniques for Radar and EW Signal Simulation
for Receiver Performance Analysis
Copyright 2004, Agilent Technologies



Agilent Technologies

Range: 316.2278 mV

Page 37

Intrinsic to baseband generators is some amount of playback memory. The amount of memory varies from model to model. This is the space where the digital representation of the waveform is held to be played back when instructed or triggered. Some off-the-shelf baseband generators include larger non-volatile storage (i.e. disk drives) so waveforms can be conveniently kept and loaded into playback memory when needed.

Sequencing

One method used in signal generation for long waveforms is segmenting and sequencing the data file. If the file contains portions that are repetitive, these segments can be replayed when needed without consuming additional memory.

An example of this would be pulsed signals that have considerable off time between pulses. This off time would be recorded as a single segment of waveform that could be replayed whenever subsequent blocks of off time occur.

Real Time Signal Generation

For testing the physical layer of communication systems time varying data must be placed in the various logical channels of the air interface. Generally, this is done by generating a pseudo random data sequence that simulates physical layer traffic. For many cases this is inadequate since the data is essentially useless for simulating and initiating air interface processes such as paging, acquisition, channel assignment, etc.

Baseband Studio for Waveform Streaming

*Onboard RAM resides on the Baseband Studio PCI card

Key Features

- **Continuous I/Q waveform streaming**
(direct from PC HDD or onboard RAM* to ESG/PSG)
- **Virtually unlimited waveform length**
(scalable with disk drive technology)
- **Up to 40 MSa/s & 32 MHz RF modulation BW**
(scalable with disk drive & PC technology)
- **Up to 100 MSa/s & 80 MHz RF modulation BW**
(512 MSa memory (5.12 seconds) with onboard RAM)
- **Set playback characteristics**
 - Playback once, N times, or infinitely
 - Playback when triggered
- **Supports external HW and SW triggering**
- **Selectable waveform format**
 - 16-bit I/Q
 - 15-bit I/Q w/ 2 markers
 - 14-bit I/Q w/ 4 markers
- **Automation using the Microsoft .NET API**

Techniques for Radar and EW Signal Simulation
for Receiver Performance Analysis
Copyright 2004, Agilent Technologies

Page 38

The features of Baseband Studio for waveform streaming include:

Continuous I/Q waveform streaming – Long time records of signals created and formatted in common signal creation environments, including Agilent ADS, MATLAB, and other system design tools are easily played back using Baseband Studio for waveform streaming provided the waveform is created in the correct file format.

Long, unique waveforms - Waveform streaming from a PC HDD enables virtually unlimited I/Q waveform file size. The only limitation is the space available on your PC hard drive or RAID configured drive array.

High sample rate and wide BW - Sample rates of up to 40 MSa/s can be achieved. This translates into 16 MHz of bandwidth for each of the I and Q channels and a total of 32 MHz RF modulation bandwidth. This wide bandwidth enables simulation of multiple channels of communication signals and generation of pulsed waveforms.

Streaming control - Full control of the streaming process is provided from the software's GUI or API. The stream can be started, stopped, looped a specified number of times, or played continuously. When the waveform ends the user can select whether the terminal value should hold the value of the last sample or be set to zero.

Marker functionality - Output markers enable synchronized control and triggering at a specific point or portion of your waveform. Support for 0, 2, or 4 software markers is provided. Markers are embedded in the waveform file by using bit 0 and bit 1 of the I/Q pair.

Utilize the Microsoft .NET-based API - Use the Microsoft .NET-based application programming interface (API) to configure and launch hard drive streaming directly from your test executive rather than from the Baseband Studio for waveform streaming graphical user interface. The entire signal configuration and streaming process can be automated in your own programming environment. The software's built in Help system provides .Net programming examples. These examples can be easily leveraged to minimize the programming and automation learning curve.

Certainly, the configuration of the PC and associated hard drive will have a major impact on the performance of the streaming capability. Careful consideration of the end-to-end throughput of the data path is important when selecting the PC and hard drive system.

Record and Playback Long Waveforms

Take your waveform simulation to the next level...

- Record signals off the air with the 89600 VSA
- Transfer files to a PC equipped with Baseband Studio
- Stream them into the PSG or ESG signal generator for playback



Techniques for Radar and EW Signal Simulation
for Receiver Performance Analysis
Copyright 2004, Agilent Technologies



Agilent Technologies

Range: 316.2278 mV
Gain: 10.0000

Page 39

The cost of operating a radar test range with live targets is incredibly expensive. By recording signals and playing them back on the PSG or ESG signal generators in the lab you save time and money. Drive testing mobile communication systems such as cellular or Specialized Mobile Radio (SMR) and trying to replicate unique scenarios in the field offers challenges as well. Using the 89600 VXI hardware, unique waveforms can be captured in the field and played back in the laboratory.

The file format must be converted to binary in order to be compatible with Baseband Studio for waveform streaming. A free utility is available from Agilent to facilitate this conversion. Eventually, we anticipate the 89600 software will be able to record directly into the proper format for streaming.

The maximum sample rate of the 89600 (w/ VXI mainframe) is 95 MSa/s for both I & Q. This translates to a maximum RF modulation bandwidth of 36 MHz. This is more than enough since the current maximum modulation BW for Baseband Studio for waveform streaming is 32 MHz. At this sample rate the 89600 can capture 384 MSa of data which represents about four seconds of data at the highest rate. This limitation is due to the capture speed of the RAM in the 89600 VXI mainframe. At sample rates below about 11.875 MSa/s the 89600 can capture up to 768 MSa. This represents about 65 seconds of data at this sample rate.

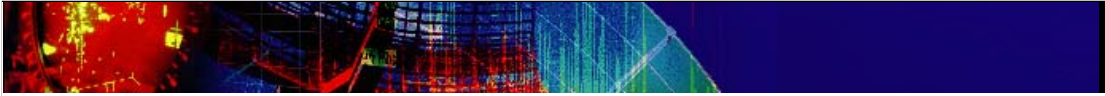

More solutions from Agilent

Fundamentals of RF Pulse Analysis using a Spectrum Analyzer

Techniques for Radar and EW Signal Simulation
for Receiver Performance Analysis
Copyright 2004, Agilent Technologies



Agilent Technologies

Range: 316.2278 mV

Page 40

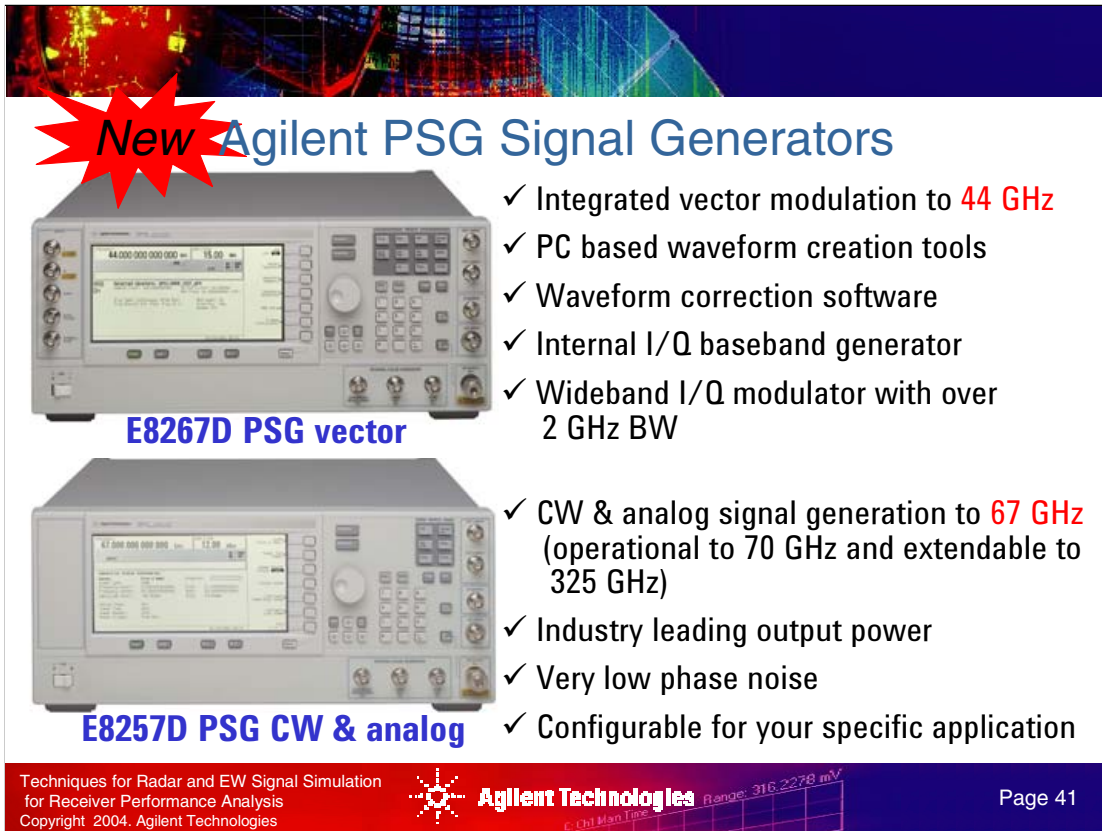

New Agilent PSG Signal Generators

E8267D PSG vector

- ✓ Integrated vector modulation to **44 GHz**
- ✓ PC based waveform creation tools
- ✓ Waveform correction software
- ✓ Internal I/Q baseband generator
- ✓ Wideband I/Q modulator with over 2 GHz BW

E8257D PSG CW & analog

- ✓ CW & analog signal generation to **67 GHz** (operational to 70 GHz and extendable to 325 GHz)
- ✓ Industry leading output power
- ✓ Very low phase noise
- ✓ Configurable for your specific application

Techniques for Radar and EW Signal Simulation for Receiver Performance Analysis
Copyright 2004, Agilent Technologies

Agilent Technologies

Range: 316.2278 mV

Page 41

Agilent signal sources address many different applications including all types of terrestrial & satellite communication systems, radar systems & avionics, as well as RF & microwave component evaluation. The requirements of these different applications varies widely in terms of phase noise, frequency hop speed, and tuning accuracy & resolution. Problems arise when developing a synthesizer to meet the broadest range of requirements for multiple applications. For instance, in PLL based synthesizer designs, reducing frequency hop speed is inversely related to reducing the phase noise of the signal source.

Phase noise is arguably the most critical characteristic for radar applications insofar as the returned signal carries much of the target information in its phase (relative to the phase of the transmitted signal). Frequency hop speed is important for the evaluation of frequency agile radars, but is not critical. Frequency agile radars represent a small subset of deployed systems and most parameters can be, and often must be, characterized with the frequency held constant.

Evaluation of RF and microwave components often requires that measurements be made rapidly over a broad range of frequencies. In this industry faster test times can be achieved with faster frequency hop speeds thereby reducing the need for additional expensive capital expenditures.

Tuning accuracy and resolution of the signal source is important to characterization of all communication systems. After all, the source used to test a system must be more accurate than the system itself to avoid adding measurement errors that could wrongly be attributed to the system under test.



Comparisons of Building Custom Radar Waveforms

	PSG with Signal Studio for pulse building software	Frequency Agile Signal Simulator (FASS)
Pulse width	10 ns (min)	10 ns (min)
Min/Max rise-time	25 ns / 500 ns	10 ns / 1 us
On/off ratio	> 80 dB (with pulse modulator enabled)	> 80 dB
PRF	Up to ~ 20 MHz (internal arb)	10 Hz – 1 MHz
Pulse compression	FM Chirp, Barker, AM Step, FM Step, QPSK, etc.	FM Chirp, Barker, AM Step, FM Step, QPSK, etc.
Frequency agility	Within 80 MHz BW of internal arb ~ 25 ns	10 MHz – 18 GHz < 100 ns
Phase coherent frequency agility	NO	YES
Level of integration	External PC + SW / Full API (.net)	External PC + SW to drive FW SCPI commands
PC Connectivity	Fast	Slow
Storage	6 Gbyte Hard Drive	Non-Volatile RAM
Waveform Creation	Signal Studio for pulse building, ADS, MatLab	WGL
Size	Small	Large system
Maintenance cost	Low	High

Techniques for Radar and EW Signal Simulation for Receiver Performance Analysis
Copyright 2004, Agilent Technologies



Range: 316.2278 mV

Page 42

This comparison of the PSG vector signal generator and the now obsolete Frequency Agile Signal Simulator (FASS) indicates that most of the functions performed by FASS can be implemented with the PSG and in some areas the PSG offers more capability. All at a price much lower than for what the FASS was sold. One limitation is that the PSG is not frequency agile over wide frequency ranges. If this capability is critical to your application, you may want to investigate the N7500 Signal Simulation and Analysis System.

Notes continued from the previous page:

The addition of digital or I/Q modulation to a signal source with an associated baseband I/Q generator not only allows the generation of waveforms needed for advanced digital communications and radar systems, but can be utilized to mitigate some of the issues around waveform quality. Correction algorithms can be applied to a waveform to reduce both linear and non-linear distortions. Waveform files can be developed to generate multiple carriers from a single signal generator. Frequencies can be switched almost instantaneously (1/sample frequency) within the bandwidth of the baseband I/Q generator.

More and more the modulation bandwidth of synthesized waveforms is becoming a critical characteristic of signal sources for both radar and communication system applications. As technologies are developed to efficiently transmit large amounts of information in limited slices of spectrum, communication systems are migrating to higher frequencies and wider bandwidth technologies. Baseband I/Q generator and I/Q modulator technologies must keep pace with these advancements in order to provide both military and commercial markets with the tools necessary to develop leading edge products.

N7500 Signal Simulation and Analysis Solutions



Features & Benefits

- ✓ **Fast switching of frequency and power**
- ✓ Get complex signals “on the air” quickly
- ✓ Convenient summing of IF and \pm Outputs
- ✓ Modularity enables multi-channel systems
- ✓ Core capability can be expanded for advanced applications

Fundamentals of RF Pulse Analysis using a Spectrum Analyzer

Techniques for Radar and EW Signal Simulation
for Receiver Performance Analysis
Copyright 2004, Agilent Technologies



Agilent Technologies

Range: 316.2278 mV
C. Ch. Max. Time

Page 43

The Agilent N7500 Series Signal Simulation and Processing Systems offer the flexibility and performance for addressing today’s complex signal environments. For applications including radar systems and satellite communications, and terrestrial microwave radio for broadband wireless access, the N7500 provides a path to success.

The N7500 Series is available in various configurations that are tailored to unique requirements. The Agilent N7501 is an example system, covering the 10 MHz to 20 GHz frequency range with 80 MHz signal bandwidth.

Throughput -- The system can switch frequency and power in less than 350 μ s, typically less than 150 μ s.

Responsiveness --The system architecture is optimized for fast response to computer commands. New complex communication signals can be online in less than 100 ms. Loopback capability built into the baseband processor enables a calibration in less than 30 seconds.

Modulation flexibility -- In addition to AM/FM/Pulse, the system offers I/Q modulation like a vector signal generator as well as an IF that gets upconverted to microwave frequencies. All this is combinable and flexible.

Scalability -- With a modular VXI form factor, multiple channel configurations are straightforward, both for the source and the receiver.

Note: The N7500 is a custom system and typically includes engineering and support services in addition to the hardware itself. Please contact your Agilent sales representative for more information.

Agilent's N6030A Arbitrary Waveform Generator

High Performance

**1.25 GS/s Sample Rate
AND 15 bit Resolution**

Memory Multiplier

**Expanded Waveform
Memory AND Advanced
Sequencing Engine**

**Available
November 2004**

System Scalability

**Stand-Alone Operation
AND System Scalable
Architecture**

Ease of Use

**Wideband AWG AND
Function Generator
AND Agilent SW
compatibility**



Fundamentals of RF Pulse Analysis using a Spectrum Analyzer

Techniques for Radar and EW Signal Simulation
for Receiver Performance Analysis
Copyright 2004, Agilent Technologies



Agilent Technologies

Range: 316.2278 mV

Page 44

Agilent's new solution to address wideband requirements is the N6030A. This is a Modular, Dual Channel, Differential Output AWG with benefits in 4 key areas:

First: Unprecedented performance. **Each** channel offers 1.25 GS/s and 15 bits of resolution.

Second: Memory Multiplication. How waveforms are replayed can make a tremendous difference in total playtime. It is a result of the N6030A's large waveform memory **AND** a sophisticated sequencing engine.

Third: System Scalability allows the instrument to be used as a stand-alone AWG **AND** as a scalable component for multi-emitter simulations.

Finally, when introduced in November this year, this AWG will come standard with software to easily create and download custom waveforms and control all aspects of the N6030A's operation. Agilent will also offer optional SW to use the AWG as a high performance Function Generator and Agilent SW applications.

Generate Wideband Waveforms

**Unprecedented
Performance**

- **1 GHz I/Q Bandwidth (using a Dual Channel configuration)**
 - 500 MHz IF Only (for a Single Channel)
- **Nanosecond Switching Speeds within a 1 GHz Bandwidth**
- **Generate Phase Coherent Signals within a 1 GHz Bandwidth**
 - Multitone
 - Multichannel

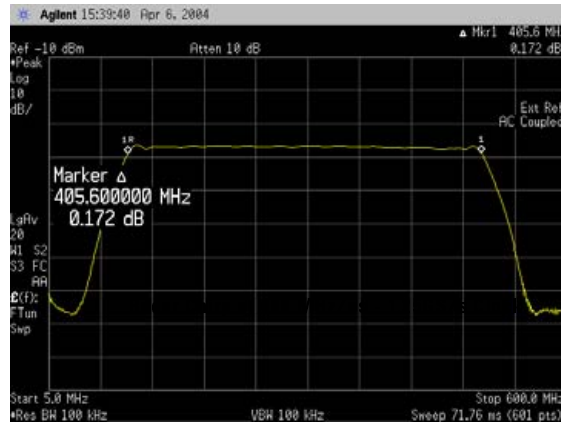

Fundamentals of RF Pulse Analysis using a Spectrum Analyzer

Techniques for Radar and EW Signal Simulation
for Receiver Performance Analysis
Copyright 2004, Agilent Technologies



Agilent Technologies

Range: 316.2278 mV
E-Channel Loss

Page 45

Wideband waveforms are possible because of full 1 GHz of modulation BW.

That 1 GHz of BW also allows you to hop narrow-band signals at ns rates.

You can also use the 1 GHz of BW to generate multiple phase-coherent tones and channels for satellite and EW simulations, respectively.



Waveform Creation & Generation Demonstration

Visit our websites at:

www.agilent.com/find/psg

www.agilent.com/find/basebandstudio

www.agilent.com/find/signalstudio



Techniques for Radar and EW Signal Simulation
for Receiver Performance Analysis
Copyright 2004, Agilent Technologies



Agilent Technologies

Range: 316.2278 mV
6.013801E5

Page 46



Summary

- **Commercial-off-the-Shelf (COTS) vector arbitrary waveform generators with deep memory can offer a lower cost and often more capable alternative to customized testing methods for many radar & EW applications**
- **Agilent has the tools to create and generate radar waveforms**
 - **PSG vector signal generator with wideband capability**
 - **Multi-source phase coherency**
 - **I/Q waveform files created using Agilent ADS or MatLab are easily downloaded into the PSG**
 - **Signal Studio for pulse building**
 - **Baseband Studio for waveform streaming**
 - **N7500 Signal Simulation and Analysis Solution**

Thank You for your Attendance!!!

Fundamentals of RF Pulse Analysis using a Spectrum Analyzer

Techniques for Radar and EW Signal Simulation
for Receiver Performance Analysis
Copyright 2004, Agilent Technologies



Agilent Technologies

Range: 316.2278 mV

Page 47

Thank you for attending today.

Find out more about Waveform Streaming and other Agilent Baseband Studio products at: www.agilent.com/find/basebandstudio

Find more information about the Agilent ESG & PSG signal generators at:

www.agilent.com/find/esg
www.agilent.com/find/psg



Q & A

Fundamentals of RF Pulse Analysis using a Spectrum Analyzer

Techniques for Radar and EW Signal Simulation
for Receiver Performance Analysis
Copyright 2004, Agilent Technologies



Agilent Technologies

Range: 316.2278 mV
[Grid pattern]

Page 48

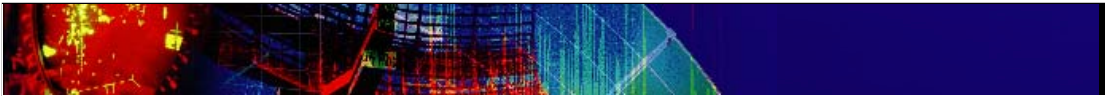

Web References

- www.agilent.com/find/signalgenerators
- www.agilent.com/find/psg
- www.agilent.com/find/basebandstudio
- www.agilent.com/find/signalstudio
- www.agilent.com/find/E6432
- www.agilent.com/find/esg
- www.agilent.com/find/phasenoise
- www.agilent.com/find/AD

Fundamentals of RF Pulse Analysis using a Spectrum Analyzer

Techniques for Radar and EW Signal Simulation
for Receiver Performance Analysis
Copyright 2004, Agilent Technologies



Agilent Technologies

Range: 316.2278 mV
C. Ch. H. A. T. P. S. E.

Page 49