

Signal Chain Noise Figure Analysis

Purnachandar Poshala, Rushil KK, Robin Gupta

ABSTRACT

This application report gives a method to calculate the effective noise figure of the whole signal chain and how knowing this helps correlate it with effective noise floor and dynamic range calculations for the last element, the analog-to-digital converter (ADC), in the receiver chain.

Contents

1	Introduction	2
2	Receiver Signal Chain	2
3	Thermal Noise.....	3
	3.1 Important Properties of Thermal Noise	3
4	Thermal Noise as Reference.....	5
5	Definition of Noise Factor	5
6	Calculating Noise Added by the Device from Noise Factor	6
7	Effective Input Referred Noise	7
8	Dynamic Range Requirements of Signal	7
9	Equivalent Noise Factor for a Cascade of Networks.....	7
10	General Formula and Important Observations.....	8
	10.1 Observations	8
11	Example Test Case.....	9
12	Defining GAIN + NOISE Factor Parameters for RF Amplifier + Real Mixer + Tunable Band-Pass Filter + ADC:	10
	12.1 Calculating Noise Factor for the Set-Top Box Signal Chain.....	12
	12.2 Important Derivations and Observations from the Previous Example.....	12
13	Conclusion	13

List of Figures

1	Receiver Signal Chain	2
2	Constant Current.....	3
3	Thermal Noise.....	3
4	Frequency Range of Power Spectral Density	4
5	Thevenin Equivalent Shown in the Box for any Network of Resistors	4
6	Definition of Noise Factor	6
7	Equivalent Noise Factor for Cascaded Networks	7
8	Components of Noise	8
9	Typical Set-Top Box Signal Chain.....	9
10	Analog Input vs. Digital Output Curve for 3-Bit ADC	10
11	Combining Different Elements of Set-Top Box Signal Chain.....	12

1 Introduction

Noise figure is a parameter that is specified in the data sheets of many devices present in the signal chain like the LNA, mixer, amplifier, and active filters as a measure of the noise added by the device. This document discusses the relevance of this parameter with respect to signal chain and how to correlate it to calculate the total noise added by all the devices, and therefore, the effective noise floor.

2 Receiver Signal Chain

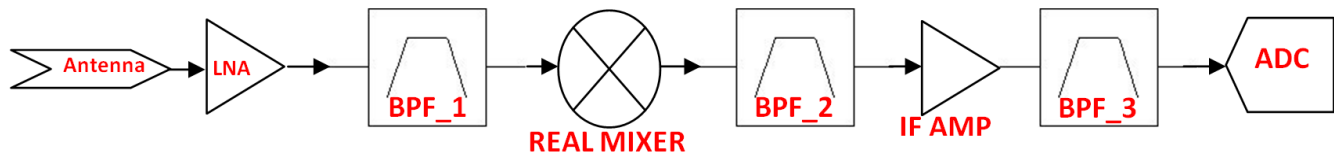

Figure 1. Receiver Signal Chain

- (a) **LNA:** The RF signal received from the antenna is fed to the LNA. This application note shows that the effect of noise from subsequent stages in the receiver signal chain is reduced by the gain of LNA, while the noise of LNA itself is directly injected into the received signal. Thus, it is imperative for LNA to boost signal power while adding as little noise and distortion possible. A good LNA has high amplification, low noise figure (NF), and should have a large compression point (P1 dB).
- (b) **BPF_1:** The antenna in the front end might pick up a lot of out-of-band signals which, after the mixer stage, will fall in band of interest. Therefore, it is necessary to filter out those components before the mixer stage. A good filter will have input/output impedance matching for maximum power transfer and also least insertion loss at the frequency of interest.
- (c) **Real Mixer:** The mixer brings down the received RF signal to IF signal for ease in further processing like filtering, amplification, and digitization. A good mixer has as little attenuation as possible and the noise figure will be less.
- (d) **BPF_2:** This is essentially an image rejection filter, particularly required in real architecture. Depending on the requirements, it can be also an LPF. A good filter has input/output impedance
- (e) **IF AMP:** This is generally required for three purposes in the signal chain.
 - First** – meet the dynamic range specifications at the input of ADC. Every ADC has a minimum power specification at its input for a given signal-to-noise ratio (SNR), depending on the input peak to peak of ADC and resolution. If the signal strength is not enough after BPF_2, then it needs to be amplified to the level of the minimum power requirement specification.
 - Second** – in DC coupling applications to generate the required common mode for the ADC.
 - Third** – convert single-ended input to differential, which is generally the requirement at the ADC input.
 A good IF amplifier should be as much linear as possible across the frequency of interest and with high enough gain to make the input signal reach the required specifications at the ADC input.
- (f) **BPF_3:** As the response of IF AMP is non-linear, all the harmonics components and inter-modulation components after digitization (ADC) are going to fall in the first Nyquist Zone. Hence, the spurious-free dynamic range (SFDR) and SNR performance can drastically come down. To overcome this issue it is better to pass the signal beforehand through a band-pass filter. This helps in removing coupled noise with the channel.
 - A low pass filter can also be used, depending upon the use case and system requirements.
 - A good filter has input/output impedance matching for maximum power transfer and also least insertion loss at the frequency of interest.

All the three elements present in the signal chain (LNA, Mixer, and amplifier) contribute to the system noise floor and thereby, it becomes imperative to understand the contribution of each element present to the overall noise floor.

3 Thermal Noise

Constant voltage across the ideal resistor provides a constant current, independent of time (see Figure 2).

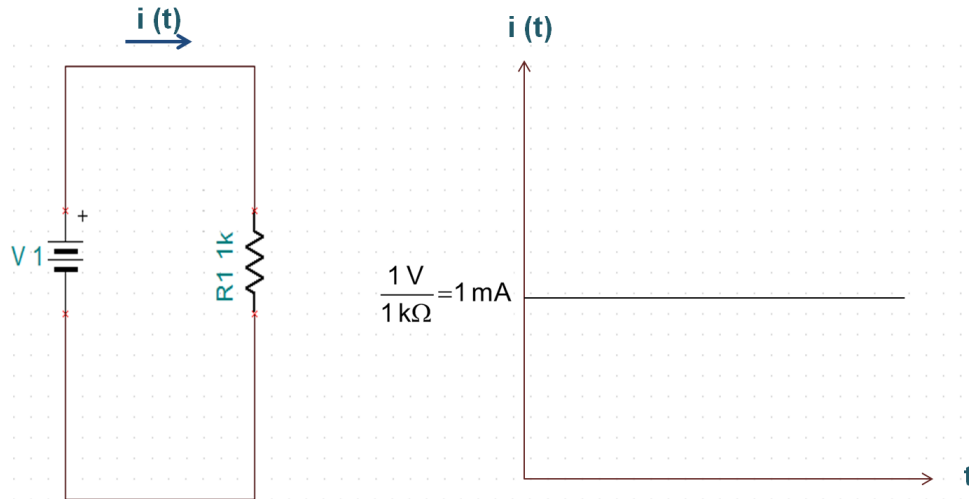

Figure 2. Constant Current

In a physical resistor, electrons randomly collide with lattice atoms due to thermal energy, giving rise to small current variations over time. The small current variation is called thermal noise (see Figure 3).

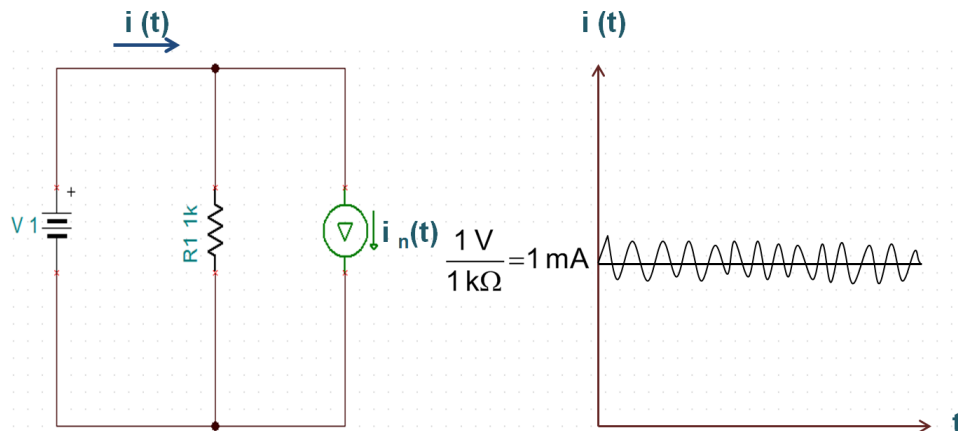

Figure 3. Thermal Noise

3.1 Important Properties of Thermal Noise

1. Thermal noise is present in any conductor
2. Thermal noise is independent of DC current flow
3. The power generated by thermal noise is spread up to very high frequencies ($1 / \tau \approx 6 T \text{ad seconds}$)
4. The only predictable property of thermal noise is its average power
5. The so-called power spectral density shows how much the signal carries at a particular frequency
6. In the case of thermal noise, the power is spread uniformly up to very high frequency (about a 10% drop at 2 THz)
7. The spectral content of the thermal noise is 'white', meaning that power spectral density of thermal noise is constant over the whole frequency range

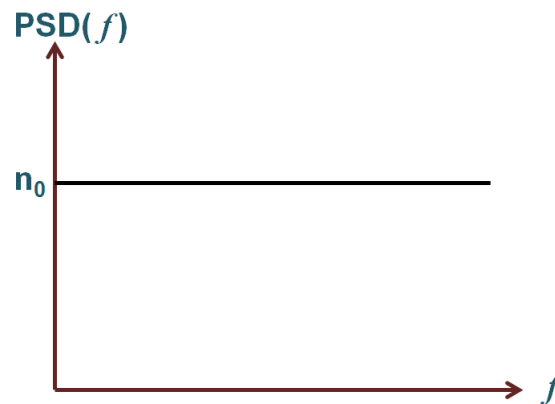

Figure 4. Frequency Range of Power Spectral Density

As the distribution of the noise is white, the total amount of thermal noise added can be calculated by integrating per-hertz thermal noise over the band of interest. Therefore, thermal noise increases with an increase in the bandwidth of observation.

Also, clearly the kinetic energy of the thermally agitated particles will increase with an increase in absolute temperature, meaning higher thermal noise spectral density.

The root-mean square (RMS) thermal noise voltage for a resistance R is given by:

$$v_n = \sqrt{4kTBR} \quad (1)$$

Where:

v_n is the equivalent noise voltage.

k is the Boltzmann constant (1.38×10^{-23} J/K).

T is the device temperature under test.

B is the bandwidth of observation.

R is the equivalent resistance of the network.

Any network of resistances can be reduced to a Thevenin equivalent of a single noise source voltage in series with the Thevenin equivalent resistance of the network.

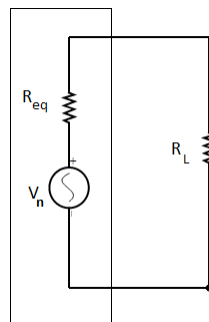

Figure 5. Thevenin Equivalent Shown in the Box for any Network of Resistors

Where R_{eq} is the effective resistance of the network and R_L is the effective load resistance.

According to the maximum power transfer theorem, the maximum thermal noise power that can get coupled with load resistance is when:

$$R_L = R_{eq} \quad (2)$$

Then, the power across R_L can be given as:

$$P_n = \frac{(v_n / 2)^2}{R_L} \quad (3)$$

From [Equation 1](#),

$$P_n = \frac{4kTBR_{eq}}{4R_{eq}} \quad (4)$$

From [Equation 4](#),

$$P_n = kTB \quad (5)$$

[Equation 5](#) is the maximum thermal noise power that can be coupled from a noisy network.

Typically, the thermal noise is specified as the Power Spectral Density (PSD), given as power density per hertz.

From [Equation 5](#):

$$PSD = kT \quad (6)$$

4 Thermal Noise as Reference

To carry out the noise figure analysis, a reference noise is required. For this purpose, thermal noise is injected into the system at 290 kelvin.

The PSD of the injected thermal noise at 290 kelvin, as per [Equation 6](#) can be calculated to be **-174 dBm / Hz**.

To calculate the effective noise power of the thermal noise injected into the system over the frequency of interest, then PSD is integrated over the band.

Example: If the band of interest is 1 MHz, then the effective thermal noise power comes out as:

$$-174 \text{ dBm / Hz} + 10\log_{10}(10^6) = -114 \text{ dBm / 1 MHz.}$$

5 Definition of Noise Factor

Noise factor of a network is defined as the ratio of signal-to-noise ratio (SNR) at the input to the SNR at the output.

$$F = \frac{SNR_i}{SNR_o} \quad (7)$$

Where SNR_i is the signal-to-noise ratio at the input of the network and SNR_o is the signal-to-noise ratio at the output of the network.

This can also be specified as noise figure (NF) in logarithmic units as:

$$NF = SNR_{i_{dB}} - SNR_{o_{dB}} \quad (8)$$

From [Equation 8](#), it can be inferred that NF is a measure of degradation of the SNR from input to output.

We can rewrite [Equation 7](#) as division of respective signal power density to noise power density at input and output as:

$$F = \frac{S_i / N_i}{S_o / N_o} \quad (9)$$

Where:

- S_i is the signal power density at the input of the network.
- N_i is the noise power density at the input of the network.
- S_o is the signal power density at the output of the network.
- N_o is the noise power density at the output of the network.

To understand [Equation 9](#) further, it is assumed that a signal with a power density of S_i is input to the system which amplifies it by a power gain of G and adds a certain amount of noise N_x to the input.

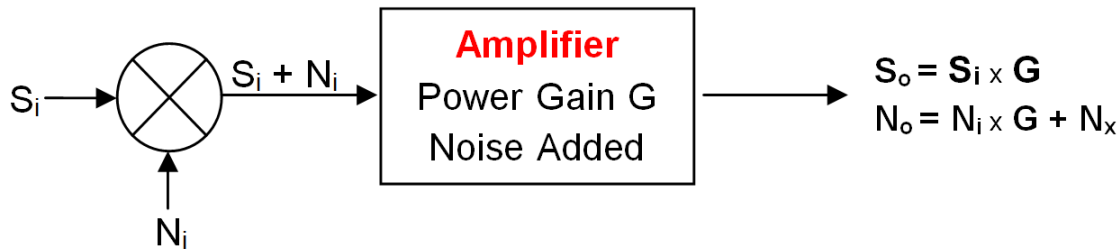
Figure 6. Definition of Noise Factor

Equation 9 can be further written depending on Figure 6 as:

$$F = \frac{1/N_i}{G/(N_x + G \times N_i)} \quad (10)$$

From Equation 10

$$F = \frac{(N_x + G \times N_i)}{G \times N_i} \quad (11)$$

From Equation 11, it is clear that the noise factor increases in proportion to the noise added by the system. If the noise added by the system is zero, then the value of the noise factor will be 1, which is the minimum possible value.

Now, to calculate and standardize the noise figure calculations across different devices reference, N_i needs to be same.

Hence, the reference input noise across different devices is thermal noise injected at 290 kelvin with per hertz power spectral density of -174 dBm.

6 Calculating Noise Added by the Device from Noise Factor

Having established that thermal noise is used as reference (N_i) to specify F , then Equation 11 can be written further by replacing N_i with kTB .

$$F = \frac{N_o}{G \times N_i} \quad (12)$$

From Equation 5 and Equation 11:

$$F = \frac{(N_x + G \times kTB)}{G \times kTB} \quad (13)$$

From Equation 13:

$$F = \frac{N_x}{G \times kTB} + 1 \quad (14)$$

From Equation 14:

$$N_x = (F - 1)GkTB \quad (15)$$

For input noise of kTB , the output noise power is given as (Equation 16).

From Equation 12

$$N_o = FkTBG \quad (16)$$

7 Effective Input Referred Noise

The total noise power calculated at the output of the device is referred to the input to calculate the dynamic range calculations at the input of the device (minimum SNR required).

$$\text{Input Referred Noise Power } (N_{o_i}) = N_o / G \tag{17}$$

Where N_o is the total output noise power and G is the gain added by the device.

From Equation 16:

$$N_{o_i} = N_o / G = FkTB \tag{18}$$

8 Dynamic Range Requirements of Signal

Generally a received signal from the antenna needs to maintain a minimum SNR throughout the signal chain, otherwise, it is not possible to reconstruct the signal back in the digital domain.

To do so, calculate the effective noise floor at the input of each device.

Therefore, using Equation 18, the effective noise floor at the input of each device can be determined and thereof if the received signal is meeting dynamic range (minimum SNR) requirements.

9 Equivalent Noise Factor for a Cascade of Networks

As per the Figure 5, consider the first two active elements in the signal chain (LNA + Mixer) and try to find out the effective noise figure for the cascade of two elements.

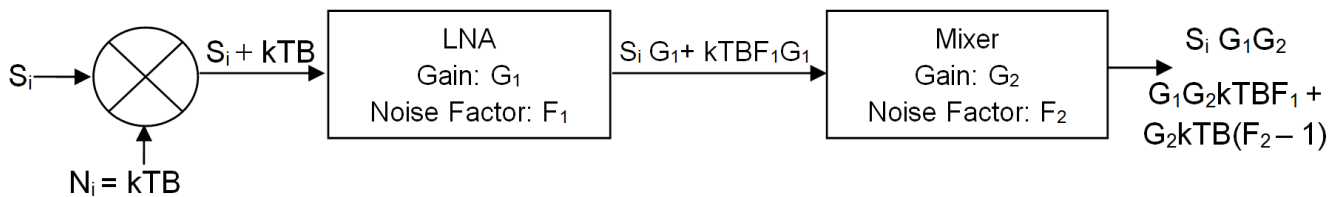

Figure 7. Equivalent Noise Factor for Cascaded Networks

As per the first stage in the previous block diagram, the input signal is S_i and noise injected is kTB . The output signal power after the first stage is

$$S_{o1} = S_i G_1 \tag{19}$$

As per Equation 16

$$N_{o1} = F_1 \times kTB \times G_1 \tag{20}$$

The total signal + noise power at the output of first stage is:

$$P_{O1} = S_i G_1 + F_1 \times kTB \times G_1 \tag{21}$$

S_{o1} and N_{o1} from the first stage are input to the second stage in the signal chain.

Signal power after the second stage can be written as

$$S_{o2} = G_1 G_2 \times S_i \tag{22}$$

From Equation 14, Equation 15, and Equation 16 it is that clear noise figure for a device is always calculated with respect to thermal noise as reference. But in the previous case, device 1 as per Equation 20 is adding some extra noise power to the input noise and feeding it to the second stage.

To calculate the total noise power at the output of stage 2, calculate the noise added by the device with respect to thermal noise as a reference at the input and the remaining input noise power getting amplified by stage 2.

The noise in Equation 20 can be divided into two noise power's spectral density.

1. Thermal noise (Reference Noise $N_{o1\text{Ref}}$) kTB
2. Remaining noise ($N_{o1\text{Remain}}$) $F_1 \times kTB \times G_1 - kTB$

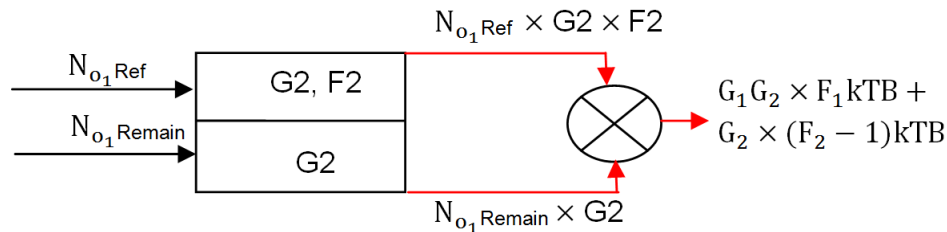

Figure 8. Components of Noise

$$\text{Therefore, } N_{o2} = G_1G_2 \times F_1kTB + G_2 \times (F_2 - 1)kTB \quad (23)$$

Using Equation 7, Equation 22, and Equation 23 the effective noise figure can be written as:

$$F = \frac{S_i / N_i}{S_{o2} / N_{o2}} \quad (24)$$

$$F = \frac{S_i / kTB}{G_1G_2S_i / (G_1G_2F_1kTB + G_2(F_2 - 1)kTB)} \quad (25)$$

Solving Equation 25:

$$F = \frac{1}{G_1G_2 / (G_1G_2F_1 + G_2(F_2 - 1))} \quad (26)$$

Equation 26 can be further simplified to Equation 27:

$$F = F_1 + \frac{F_2 - 1}{G_1} \quad (27)$$

10 General Formula and Important Observations

Using Equation 27 as a reference, the noise figure formula can be extended to N cascaded devices as below:

$$F = F_1 + \frac{F_2 - 1}{G_1} + \frac{F_3 - 1}{G_1G_2} + \dots + \frac{F_N - 1}{G_1G_2 \dots G_{N-1}} \quad (28)$$

10.1 Observations

- The effective noise factor can be reduced marginally by increasing the gain of first stage.
- If the gain of the first stage is increased sufficiently, then the effective noise factor will be the noise factor of the first stage without an impact on the subsequent stages.
- This means the design of first stage is most critical. Ideally, it should have very high gain and very low noise factor. This requirement poses a need to always have LNA in the front end (an amplifier with low noise factor and high gain).

11 Example Test Case

To validate the previous claims and formulas, a real-time example of a satellite set-top box was considered:

A typical satellite set-top box has a low-noise block converter (LNB) at the Antenna front end which receives the Ku Band signal and down-converts it into an L-band or S-band signal to carry it over coaxial cable from the LNB to the set-top box.

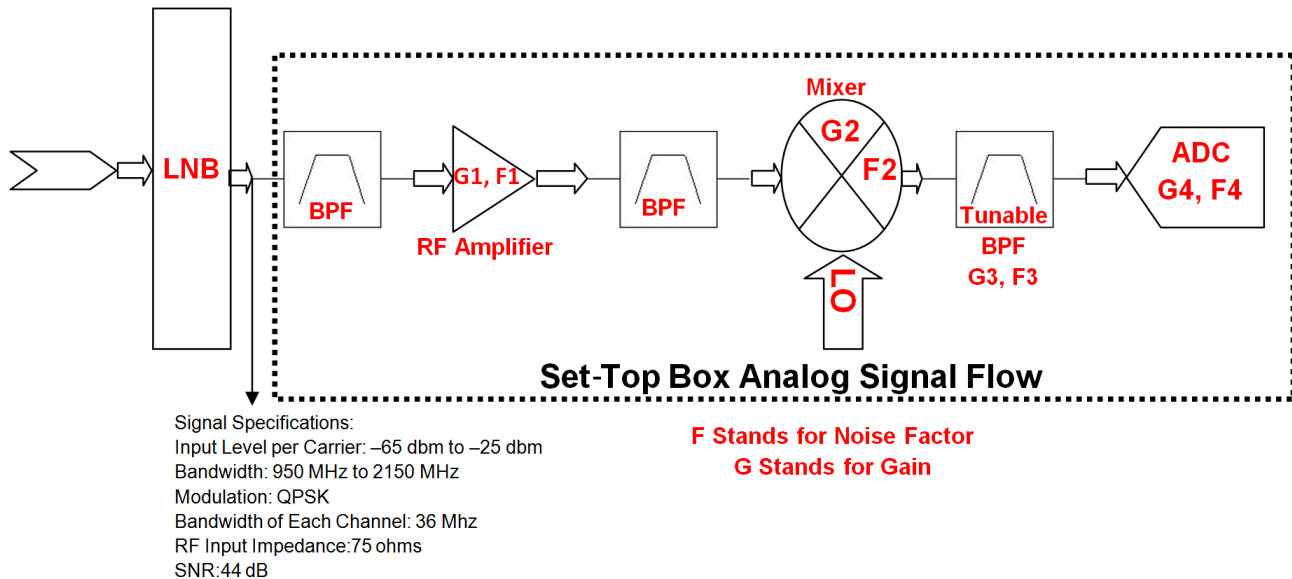

Signal specifications are taken as an example from norms set by the Indian government for satellite set-top boxes.

Figure 9. Typical Set-Top Box Signal Chain

1. **LNB (Low-Noise Block Converter):** This is the first device in the receiver signal chain for a satellite set-top box. This is assembled right below the antenna. The main function of the block is to convert Ku band signal to L band or S band signal. This is required to down-convert the received signals so that they are easily transmitted over the coaxial cable without much loss in the signal.
2. **RF Amplifier:** The second element inside the set-top box after the band-pass filter is an RF amplifier whose function is to amplify the input signal up to a level that even after subsequent attenuation stages, the signal meets the minimum power specifications at ADC input.
3. **Real Mixer:** The input signal present at the set-top box input is down-mixed to a lower IF frequency. In case of under mixing this can vary from 500 MHz to 850 MHz.
4. **Tunable Band-Pass Filter:** As per the input signal specifications, each channel constitutes 36 MHz of bandwidth. The tuner is a tunable band-pass filter which is used to select the desired 36-MHz channel. But it has a certain noise figure and attenuation associated with it.
5. **ADC:** The desired filtered channel is converted to digital data by an ADC and is sent to the FPGA for further signal processing for eventual display on the TV.

12 Defining GAIN + NOISE Factor Parameters for RF Amplifier + Real Mixer + Tunable Band-Pass Filter + ADC:

All the values chosen here are dummy values just to explain the previous noise figure concepts in a practical way. In actual physical system the values may be pretty different.

RF Amplifier: As this is the first element in the set-top box signal chain, this need to have high gain and less noise figure. The general trend for the RF amplifier currently used is:

- LNA gain (G_1) = 100(20 dB).
- LNA noise figure = 4.0 dB ($F_1 = 2.511$)

RF Mixer (Down-Converter): This mixer generally has an internal gain to compensate for the loss in mixing. Hence, the effective gain becomes 1.

- Mixer attenuation (G_2) = 1(0 dB).
- Mixer noise figure: 12 dB ($F_2 = 15.85$)

Channel Tuner: This is a tunable band-pass filter with certain active components which filters out the desired channel.

- Tuner attenuation (G_3): 10(10 dB).
- Tuner noise figure: 7 dB ($F_3 = 5.01$)

Analog Digital Converter (ADC): Generally, for all the previous devices, both the noise figure and attenuation/gain are already mentioned in the datasheet. Get the values from the datasheet.

For the ADC, both the specifications are not mentioned in the datasheet.

How to Find the Noise Figure and Gain of the ADC?

The digital output data of an ADC is scaled up or down linearly with the ADC input, the slope of the ADC input versus digital output data remains constant over the whole input range. The slope of the curve digital output versus analog input gives the gain of the ADC.

Let's consider a 3-bit ADC for calculating the gain:

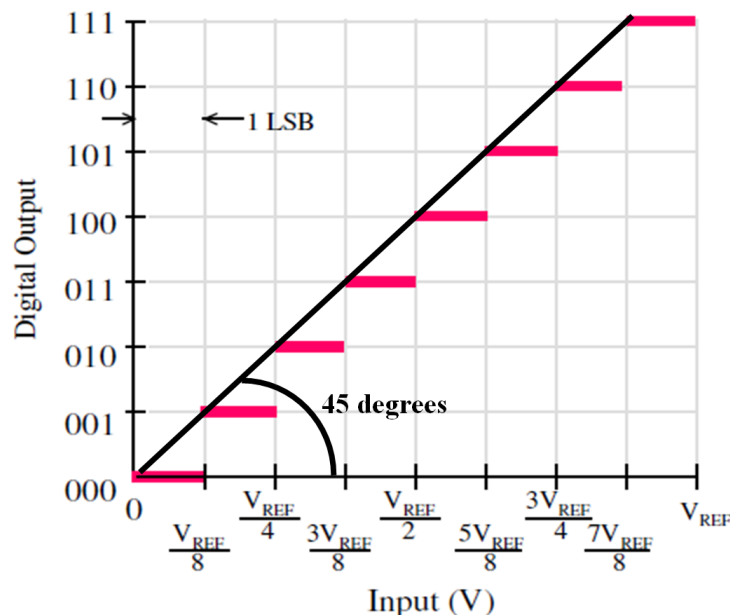

Figure 10. Analog Input vs. Digital Output Curve for 3-Bit ADC

The slope of the plot in [Figure 10](#), between the ADC analog input and ADC digital output gives the gain of the analog-to-digital converter. The slope of the curve is 45 degrees which means the gain is 1.

To calculate the noise figure, [Equation 12](#) is used.

According to the equation:

$$F = \frac{N_o}{G \times N_i} \quad (29)$$

Now, as per [Figure 10](#), the noise factor and gain can be noted as F4 and G4, respectively, for the ADC. Therefore, [Equation 29](#) becomes:

$$F4 = \frac{N_o}{G4 \times N_i} \quad (30)$$

As derived in [Equation 30](#), the gain of ADC is 1, hence $G4 = 1$.

Where N_i is the input reference thermal noise considered to be -174 dBm / Hz.

As N_i is mentioned to be per Hz, N_o is also calculated for per Hz.

Here ADC12D1600RF is used as an example to calculate the noise figure.

As per the ADC12D1600RF datasheet ([SNAS519](#)) in non-DES mode sampling at 1600 MHz, the SNR achieved is around 58 dB for an input at -0.5 dB full scale and a frequency of 500 MHz.

The ADC full scale is 600 mV, peak to peak, which translates into -0.5 dBm.

As the device is operated with an input of -0.5 dBFS, hence it means the input power is approximately -1 dBm.

To calculate the output noise power, use the SNR parameter:

$$SNR = \frac{S_o}{G \times N_o} \quad (31)$$

$S_o = S_i = -1$ dBm (because the gain is 1).

$$58 \text{ dB} = -1 \text{ dBm} / N_o$$

$$N_o = -59 \text{ dBm}$$

This PSD is calculated with respect to full Nyquist frequency of 800 MHz ($F_s / 2 = 1600 \text{ MHz} / 2$).

To calculate N_o PSD per hertz, use [Equation 32](#).

$$N_o / \text{Hz} = N_o - 10 \times \log(800 \text{ MHz})$$

$$N_o / \text{Hz} = N_o - 10 \times \log(800 \times 10^6)$$

$$N_o / \text{Hz} = -59 \text{ dBm} - 89 \text{ dB}$$

$$N_o / \text{Hz} = -148 \text{ dBm} / \text{Hz} \quad (32)$$

Now, as per [Equation 30](#):

$$F4 = \frac{N_o}{G4 \times N_i} \quad (33)$$

Taking log on both the sides:

$$NF4 = \log(N_o) - \log(N_i)$$

$$NF4 = -148 \text{ dBm} + 174 \text{ dBm} = 26 \text{ dB}$$

This can be converted into noise figure by taking the inverse log, which in this case is: **F4 = 398.10**

12.1 Calculating Noise Factor for the Set-Top Box Signal Chain

Using Equation 28, the effective noise figure for the whole signal chain is shown in Equation 34:

$$F = F_1 + \frac{F_2 - 1}{G_1} + \frac{F_3 - 1}{G_1 G_2} + \frac{F_4 - 1}{G_1 G_2 G_3} \quad (34)$$

Using the parameters defined in Section 12, the noise factor can be calculated as:

$$F = 2.511 + \frac{15.85 - 1}{100} + \frac{5.01 - 1}{100 \times 1} + \frac{398.2 - 1}{100 \times 1 \times 10}$$

$$F = 3.1068 \quad (35)$$

Therefore, the effective noise figure NF = 4.79 dB.

12.2 Important Derivations and Observations from the Previous Example

This example reflects that the first stage in the signal chain design is most critical as the overall noise figure is almost equal to the noise figure of first stage, because of its high gain, although the subsequent stages had high noise figure.

Designing the first stage with high gain limits the value of effective noise factor and also limits the role played by subsequent stages in noise calculations.

Replacing the whole signal chain by a single block

The whole signal chain for the set-top box can be replaced by a single block of noise factor 3.015 and gain of 1000(30 dB), as shown in Figure 11.

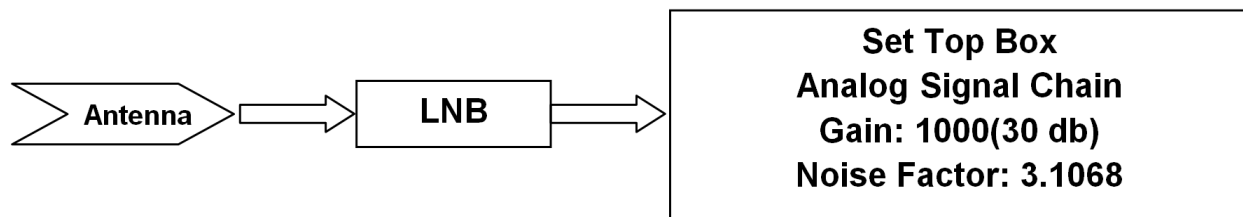

Figure 11. Combining Different Elements of Set-Top Box Signal Chain

Effective Input Referred Noise

As per Equation 18, the input referred noise can be calculated to be:

$$N_{o_i} = N_o / G = FkTB \quad (36)$$

Where:

F is the noise factor; 3.1068 in this case.

K is the Boltzmann constant.

T is the temperature, 290 kelvin for the test case.

B is the signal bandwidth, here only 36 MHz is assumed (each channel bandwidth removed by Tuner + Filter).

In dBm, input referred noise due to equivalent block is:

$$N_{o_i} = NF - 174 \text{ dBm} + 10 \times \log(B)$$

$$N_{o_i} = -93.51 \text{ dBm} / 36 \text{ MHz} \quad (37)$$

Noise Margin

As specified by Indian government standards, the minimum signal level required by the set-top box is -65 dBm.

Noise margin can be given as:

$$\text{Minimum Signal Level} - \text{Effective Noise Power} = -65 \text{ dBm} - (-93.51 \text{ dBm}) = 28.51 \text{ dB}$$

Maximum SNR achieved by ADC for the given system

Hence, the maximum SNR achieved by ADC is 28.5 dB from the perspective of noise factor.

13 Conclusion

The noise figure is a useful parameter to measure the degradation in SNR of the signal chain. Understanding how the LNA can be used to improve noise figure allows the designer to improve the overall noise performance by a large extent.

This parameter helps meet the specifications like: minimum SNR requirement from signal chain, noise margin, effective noise floor, and so forth.

Therefore, this is a useful parameter while doing signal chain analysis and needs to be accounted for with due diligence.

IMPORTANT NOTICE

Texas Instruments Incorporated and its subsidiaries (TI) reserve the right to make corrections, enhancements, improvements and other changes to its semiconductor products and services per JESD46, latest issue, and to discontinue any product or service per JESD48, latest issue. Buyers should obtain the latest relevant information before placing orders and should verify that such information is current and complete. All semiconductor products (also referred to herein as "components") are sold subject to TI's terms and conditions of sale supplied at the time of order acknowledgment.

TI warrants performance of its components to the specifications applicable at the time of sale, in accordance with the warranty in TI's terms and conditions of sale of semiconductor products. Testing and other quality control techniques are used to the extent TI deems necessary to support this warranty. Except where mandated by applicable law, testing of all parameters of each component is not necessarily performed.

TI assumes no liability for applications assistance or the design of Buyers' products. Buyers are responsible for their products and applications using TI components. To minimize the risks associated with Buyers' products and applications, Buyers should provide adequate design and operating safeguards.

TI does not warrant or represent that any license, either express or implied, is granted under any patent right, copyright, mask work right, or other intellectual property right relating to any combination, machine, or process in which TI components or services are used. Information published by TI regarding third-party products or services does not constitute a license to use such products or services or a warranty or endorsement thereof. Use of such information may require a license from a third party under the patents or other intellectual property of the third party, or a license from TI under the patents or other intellectual property of TI.

Reproduction of significant portions of TI information in TI data books or data sheets is permissible only if reproduction is without alteration and is accompanied by all associated warranties, conditions, limitations, and notices. TI is not responsible or liable for such altered documentation. Information of third parties may be subject to additional restrictions.

Resale of TI components or services with statements different from or beyond the parameters stated by TI for that component or service voids all express and any implied warranties for the associated TI component or service and is an unfair and deceptive business practice. TI is not responsible or liable for any such statements.

Buyer acknowledges and agrees that it is solely responsible for compliance with all legal, regulatory and safety-related requirements concerning its products, and any use of TI components in its applications, notwithstanding any applications-related information or support that may be provided by TI. Buyer represents and agrees that it has all the necessary expertise to create and implement safeguards which anticipate dangerous consequences of failures, monitor failures and their consequences, lessen the likelihood of failures that might cause harm and take appropriate remedial actions. Buyer will fully indemnify TI and its representatives against any damages arising out of the use of any TI components in safety-critical applications.

In some cases, TI components may be promoted specifically to facilitate safety-related applications. With such components, TI's goal is to help enable customers to design and create their own end-product solutions that meet applicable functional safety standards and requirements. Nonetheless, such components are subject to these terms.

No TI components are authorized for use in FDA Class III (or similar life-critical medical equipment) unless authorized officers of the parties have executed a special agreement specifically governing such use.

Only those TI components which TI has specifically designated as military grade or "enhanced plastic" are designed and intended for use in military/aerospace applications or environments. Buyer acknowledges and agrees that any military or aerospace use of TI components which have **not** been so designated is solely at the Buyer's risk, and that Buyer is solely responsible for compliance with all legal and regulatory requirements in connection with such use.

TI has specifically designated certain components as meeting ISO/TS16949 requirements, mainly for automotive use. In any case of use of non-designated products, TI will not be responsible for any failure to meet ISO/TS16949.

Products

Audio	www.ti.com/audio
Amplifiers	amplifier.ti.com
Data Converters	dataconverter.ti.com
DLP® Products	www.dlp.com
DSP	dsp.ti.com
Clocks and Timers	www.ti.com/clocks
Interface	interface.ti.com
Logic	logic.ti.com
Power Mgmt	power.ti.com
Microcontrollers	microcontroller.ti.com
RFID	www.ti-rfid.com
OMAP Applications Processors	www.ti.com/omap
Wireless Connectivity	www.ti.com/wirelessconnectivity

Applications

Automotive and Transportation	www.ti.com/automotive
Communications and Telecom	www.ti.com/communications
Computers and Peripherals	www.ti.com/computers
Consumer Electronics	www.ti.com/consumer-apps
Energy and Lighting	www.ti.com/energy
Industrial	www.ti.com/industrial
Medical	www.ti.com/medical
Security	www.ti.com/security
Space, Avionics and Defense	www.ti.com/space-avionics-defense
Video and Imaging	www.ti.com/video

TI E2E Community

e2e.ti.com